



HC6211FR

Ceramic hob

Installation, use and maintenance



Contents:

- 3 Important
- 4 Important Notes
- 6 Using Your Hob
- 9 Efficient Use Of Your Hob
- 10 Care And Maintenance
- 12 Troubleshooting
- 13 Fitting The Hob
- 15 How To Install The Hob
- 17 Mains Electricity Connection
- 19 Product fiche

Important

The CDA Group Ltd cannot be held responsible for injuries or losses caused by incorrect use or installation of this product. Please note that CDA reserve the right to invalidate the guarantee supplied with this product following incorrect installation or misuse of the appliance or use in a commercial environment.

This appliance is not designed to be used by people (including children) with reduced physical, sensorial or mental capacity, or who lack experience or knowledge about it, unless they have had supervision or instructions on how to use the appliance by someone who is responsible for their safety.

Under no circumstances should any external covers be removed for servicing or maintenance except by suitably qualified personnel.

Appliance information:

Please enter the details on the appliance rating plate below for reference, to assist CDA Customer Care in the event of a fault with your appliance and to register your appliance for guarantee purposes.

Appliance Model	
Serial Number	

EU Declarations of Conformity

This appliance has been manufactured to the strictest standards and complies with all applicable legislation, including Electrical safety (LVD) 2014/35/EU and Electromagnetic interference compatibility

(EMC) 2014/30/EU. Parts intended to come into contact with food conform to 1935/2004/EC.

IMPORTANT INFORMATION FOR CORRECT DISPOSAL OF THE PRODUCT IN ACCORDANCE WITH EU DIRECTIVE 2012/19/EU.

At the end of its working life, the product must be taken to a special local authority waste collection centre or to a dealer providing appliance recycling services.

Disposing of a household appliance separately avoids possible negative consequences for the environment and health. It also enables the constituent materials to be recovered, saving both energy and resources. As a reminder of the need to dispose of household appliances separately, the product is marked with a crossed-out wheeled dustbin. 

Please note:

- Ceramic hobs become hot and remain hot during and immediately after use. Do not touch the hob until it has been allowed to cool.
- Keep children away from the appliance when in use.
- Never use the hob top for storage.
- Pan handles should never stand out beyond the edge of the worktop. This will help to avoid children reaching them.
- Do not lean over the hob when it is in use.
- Follow the cleaning instructions carefully.
- Ensure the base of the saucepan is clean and dry before placing it on the hob.
- Avoid hard shocks from cookware – the vitroceramic glass surface is highly resistant but not unbreakable.

- Do not place hot lids flat on the hob top. A “suction” effect could cause damage to the hob.
- Do not drag cookware across the hob top: in the long term, this could cause damage to the hob.
- Do not store cleaning or flammable products in the unit below the hob.
- Always use appropriate cookware.
- Do not cook unopened tins of food directly on the hob.
- Never put cooking foil or plastic materials on the ceramic surface when the hob is hot. These materials could melt and cause damage to the hob.
- This hob (Class 3) has been designed for use only as a cooking appliance. Any other use should be considered incorrect and therefore dangerous.

Important

- Do not use the hob if the glass surface is cracked or damaged to prevent the risk of electric shock. Disconnect it from the power supply.
- Ensure that the power cable of a connected electrical appliance near the hob is not in contact with the cooking zones.

Using your hob

Zones:

A. Front left 1.8kW 180 mm

B. Back left 1.2kW 145 mm

C. Front right 1.2kW 145mm

D. Back right 1.8kW 180 mm

E. Power indicator

F. Residual heat indicators

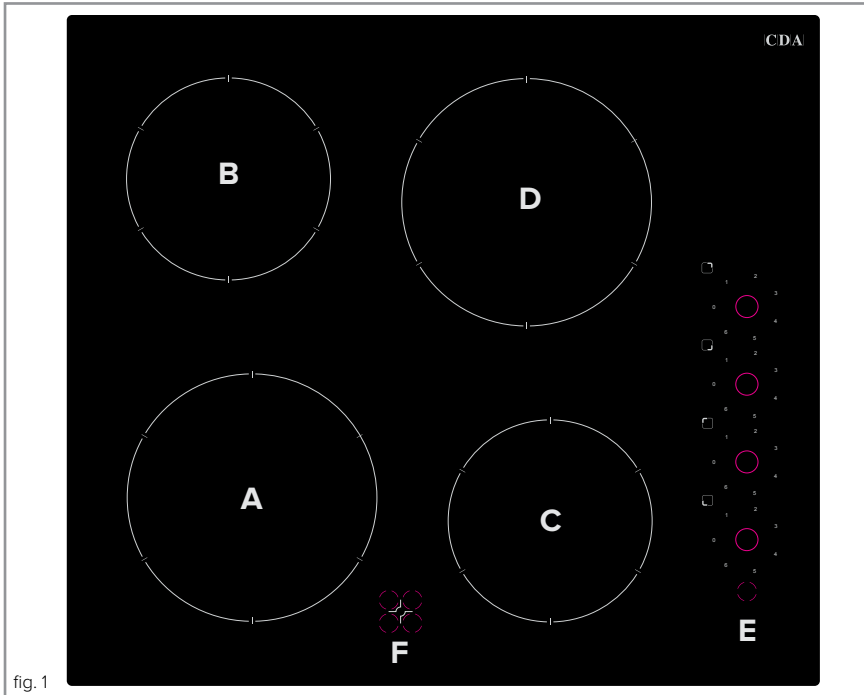

Control knob positions and ideal cooking processes

0. “Off” position

1. Low heat - stewing vegetables.

2. Low-med heat - cooking potatoes.

3. Medium heat - cooking large dishes.

4. Med-high heat - slow frying.

5. High heat - braising meat and fish.

6. Highest heat - bringing to the boil, fast frying and heating.

Using Your Hob

To switch the hob on

- Set the control knob for the desired zone to the required temperature setting. A guide to heat levels and ideal cooking processes is on page 6. The power indicator (E) will illuminate to indicate the zone's usage.

To deactivate a zone and/or switch the hob off

- Simply set the control knob(s) to the "0" position. Once all control knobs are at this position the hob will be off.
- If switching off multiple zones, the above step needs to be taken for each zone.

Please note: Any zones that are still hot to the touch (approximately 50°C or above) will be shown by their respective residual heat indicator (F).

Residual Heat Indicators

The hob is equipped with residual heat indicators to warn when any of the zones are still hot to the touch after use. A residual heat indicator  will illuminate to show if the relevant zone is approximately 50°C or above. You should avoid touching any zone whilst the hob is in use or whilst either residual heat indicator is displayed.

Please note: In the event of a power cut or failure, the residual heat indicators will illuminate after the power supply is restored. When there is no power supply to the hob however the residual heat indicators will not work, yet the hob zone(s) may still be hot, so extra care must be taken.

The residual heat indicators' layout matches that of the hob zones, as below:

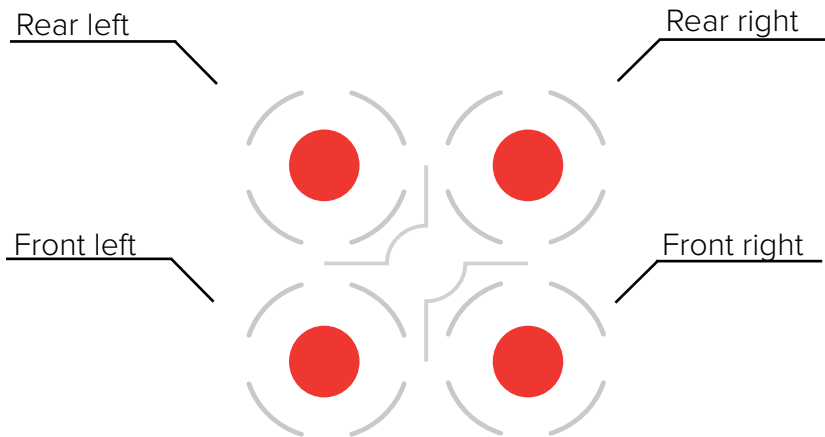

Efficient Use of Your Hob

The hob is equipped with zones designed to accommodate most shapes and sizes of pan. For best results, only use pans with flat bottoms. The most efficient use of the hob is shown below, where the pan and zone are correctly chosen. Use pan lids where possible to minimize the energy usage of your appliance.

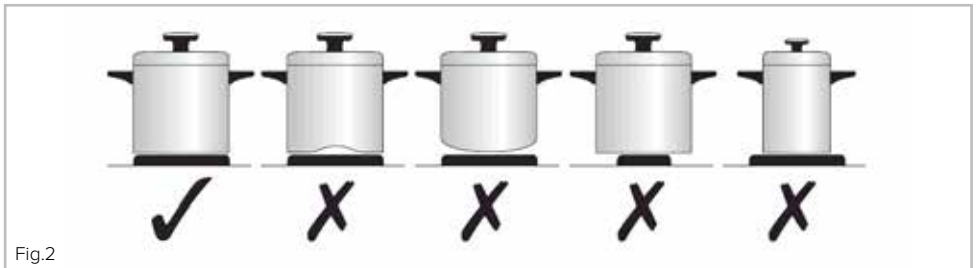

Fig.2

Zone Size	Minimum Pan Size (mm)	Maximum Pan Size (mm)
Ø 145mm	125	165
Ø 180mm	160	200

Locating a pan in the centre of the zone markings will ensure optimum efficiency.

It is very important that the pans used on the hob are made of a suitable material and have the correct type of base. The base of the pan and the hob top must be clean before use to prevent any scratches on the hob top.

Please note: Extra care should be taken if cast iron pans are used as these have coarse bases which may damage the hob top.

Care and Maintenance

Always disconnect the appliance from the power supply before undertaking any cleaning or maintenance.

Important:

- Steam cleaners must not be used when cleaning this appliance.
- You should use a non-abrasive cleaner to clean the hob top. Any abrasive cleaner (including Cif) will scratch the surface and could erase the control panel markings.
- Sugar and starch can cause permanent damage to the surface of the hob. Wipe away any spillages immediately but be careful given that the hob top will be hot during and after usage.
- Avoid letting pans boil over where possible to ensure that the need for cleaning is minimal.
- Always use a soft sponge or cloth where possible. Utensils such as scouring sponges and some brushes could cause scratches to the hob top.

Please note: A cleaning guide is available on page 11. When following the cleaning guide, please ensure any water or fluids do not encroach upon the control knobs as this may damage the hob.

Type of residue	Clean with	Cleaning advice
Light	Cleaning sponge and soft cloth	Wipe over the zone to be cleaned with a sponge and hot water, and then wipe off with a soft dry cloth.
Accumulated baked-on stains/dirt, sugar spills or melted plastics	Cleaning sponge or glass scraper and soft cloth	Wipe over the zone to be cleaned with a sponge and hot water, using a ceramic scraper to remove any large marks or stains and then wipe off with a soft dry cloth.
Rings and hard water residues	White vinegar and soft cloth	Pour a small amount of warm white vinegar onto the stain, leave it to stand, and then wipe off with a soft dry cloth.
Shiny metallic streaks	Cleaning agent for vitroceramic glass	Use specialist vitroceramic glass cleaner (preferably one with silicone for its protective properties)

If your hob is not working:

1. Check that the zone is switched on.
2. Check that the mains supply has not been switched off.
3. Check that the fuse in the spur has not blown.

In the event of a fault with the hob please advise CDA Customer Care.

Contact CDA Customer Care

A: Customer Care Department, The CDA Group Ltd, Harby Road,
Langar, Nottinghamshire, NG13 9HY

T: 01949 862 012 F: 01949 862 003

E: customer.care@cda.eu W: www.cda.eu

Troubleshooting

Problem	Possible Causes	Possible Remedy
The appliance does not work and no indicators are lit.	The appliance has no power.	Check the RCD, hob power supply and fuse and replace fuse if blown.
The appliance switches itself off.	There is an issue with the installation or the internal wiring of the hob. The RCD has tripped.	Contact your installer if appliance is new. Check if tripped, and reset RCD if necessary.
Residual heat indicator has extinguished despite zone(s) still being hot.	The appliance has no power. The temperature of the zone is below the acceptable threshold (approximately 50°C).	Check the fuse and replace if blown. Avoid touching the ceramic surface directly for some time after use.
Hob top is broken, cracked and/or chipped.	Stop using the appliance immediately and switch the appliance off at the mains. Contact CDA Customer Care to arrange a repair (contact details on page 11).	
A fault has not been resolved by any suggested remedies.	Contact CDA Customer Care using the contact details on page 11 to arrange a service visit.	

Should the above steps not resolve an issue, please contact CDA Customer Care for assistance. Contact details are on page 11.

IMPORTANT - PLEASE NOTE: In the event of any breakage, crack or cracking – even minimal – of the vitroceramic glass, immediately disconnect your appliance to prevent a risk of electric shock and contact CDA Customer Care.

Fitting the Hob

Unpacking the hob:

Take care not to lose, drop or mishandle any parts.

Fitting position of the hob:

This appliance must be installed a minimum of 55mm away from any adjacent vertical surfaces, e.g. a tall cupboard end panel. These dimensions are shown in Fig.7 on page 15. If installing the hob in a cupboard unit, or above a drawer, then a partition panel must be used.

Ventilation requirements:

This appliance must be installed to allow air to flow freely to the air intake and from the air outlet. An air gap of 25mm is recommended immediately below the hob. Failure to allow sufficient ventilation could cause problems with operation or damage to the hob and constitutes incorrect installation, which is not covered by the product's warranty (Figs. 3 and 4).

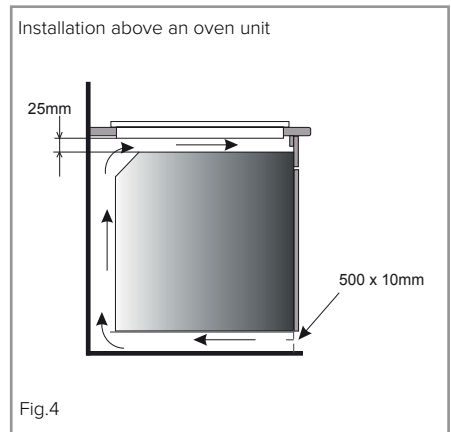
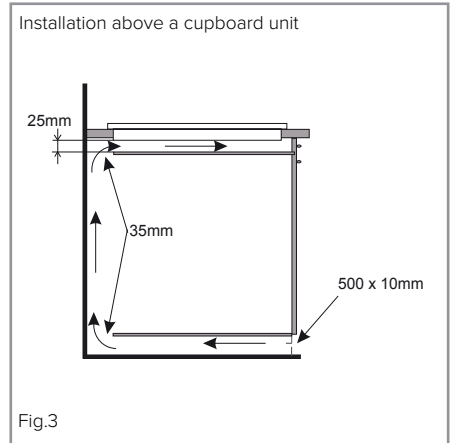

If fitting a cooker hood above the hob:

If a cooker hood is to be installed above the hob, the height of the hood above the hob must be at least 600mm (650mm is recommended) (Fig.5). If the instructions supplied with the hood dictate that the hood must be installed at a height greater than 600mm, then that height is the minimum required.

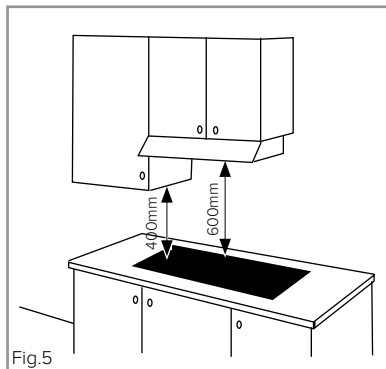

Wall furniture requirements:

The minimum height of any cabinet immediately above the hob is 900mm. The minimum height of any adjacent units (including light pelmets) is 400mm, unless they are manufactured from a material resistant to fire (steel, for example).

Important notes:

- Do not position this appliance above a refrigeration unit. The heat generated may cause the refrigeration unit to fail.
- This appliance is designed to be installed into cabinet units, and around worktops, capable of withstanding temperatures of 100°C+
- Never place perishable foods, cleaning products or flammable items in the cupboard below the appliance.
- If the hob is to be located above a working drawer, we recommend that the drawer is not used for storing soft items, for example dusters or towels; this is to minimise the risk of the cooling system air intakes being obstructed.
- Do not use silicone or similar sealants to seal the hob into place. It should always be accessible for servicing etc.

How to Install the Hob

Overall dimensions of the hob:

Width: 575 mm Depth: 510 mm

Worktop cut-out dimensions:

Width: 560 mm Depth: 495 mm

1. Make the required hole in the worktop.

Before doing this, you must check the

instructions supplied with any cooker hood to ensure that you will have the required clearance. The cutout in Fig.7 shows a minimum 50mm gap from the rear wall or splashback to the cut out edge

2. Make sure that the worktop is clean and dust free and insert the hob into the cut-out opening. Press the hob firmly into place so that the seal connects with the worktop (Fig. 6).

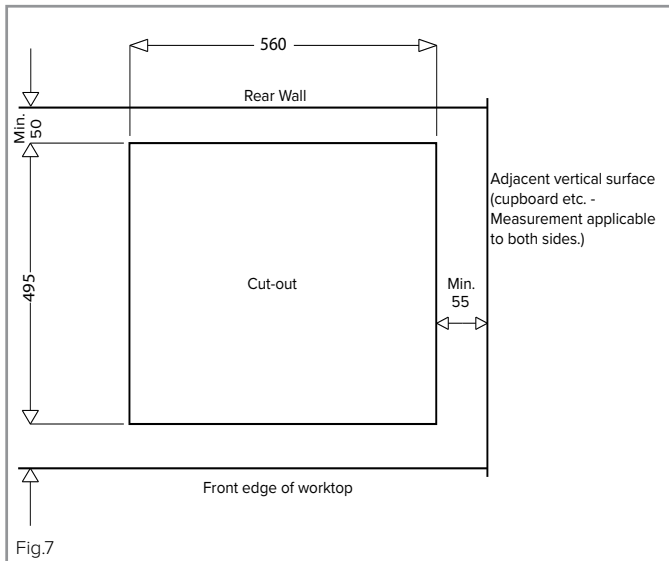
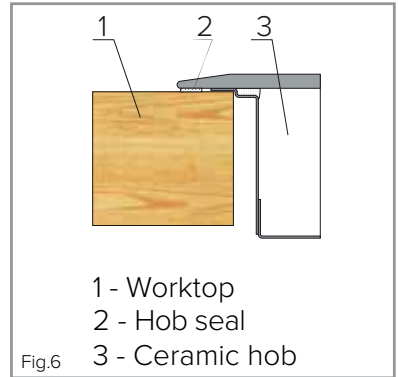

If fitting the hob into a 28-48mm worktop:

The four fixing clips marked with a 'B' should be used, as per fig. 9.

If fitting the hob into a 48mm+ worktop:

The four fixing clips marked with a 'A' should be used, as per fig. 8.

Position the fixing brackets perpendicularly to the hob's edge and tighten firmly. **Do not use power tools to do this.**

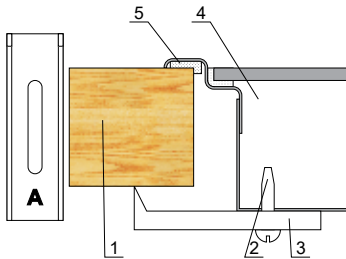

Fig.8

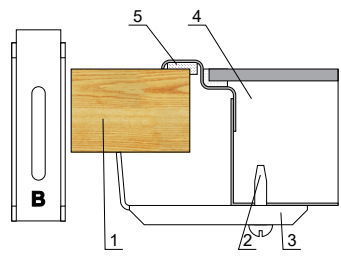

Fig.9

1. worktop
2. screw
3. fixing bracket
4. hob
5. seal

1. worktop
2. screw
3. fixing bracket
4. hob
5. seal

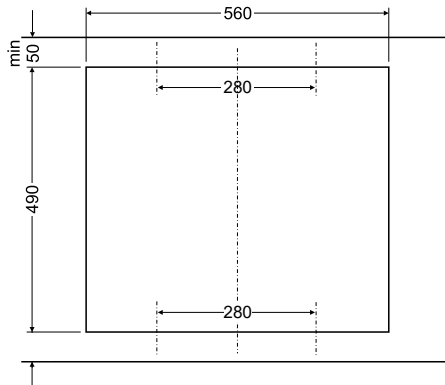

Fig.10

Mains Electricity Connection

Warning! This appliance must be earthed.

This appliance must be connected by a qualified electrician, or a similarly competent person, who is a member of the N.I.C.E.I.C. and who will comply with the I.E.T. and local regulations.

This appliance is intended to be connected to fixed wiring and is not suitable for connection to a 13A plug or 13A supply.

This appliance is intended to be connected to fixed wiring by a double pole switch, having a contact separation of at least 3mm in all poles. The switch must be positioned no further than 2m from the appliance.

Please note:

- The mains cable must only be replaced by a qualified electrician or service engineer and must be of equivalent or better rating (i.e. 4mm², HO5VV-F).

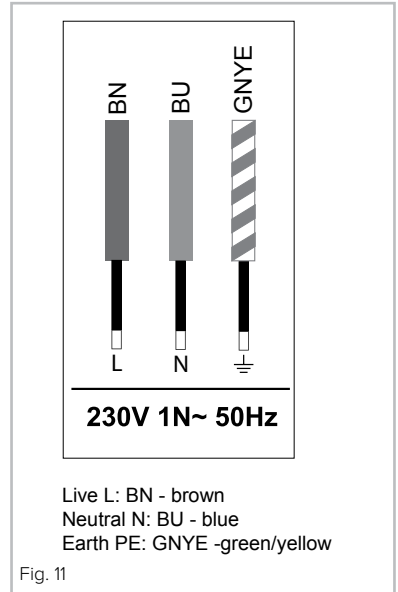

- This appliance is intended to be connected to the mains supply with a cable of cross sectional area 4mm².
- The current rating of the fuse or circuit breaker protecting this appliance should be marked on the socket outlet.
- Assembly and electrical connection should be carried out by specialised personnel.
- When installing this product we recommend you seek the help of another individual.
- **Should the mains cable be damaged or need to be replaced, it should only be done so by a qualified electrician or engineer. The connections to the hob are shown below;**

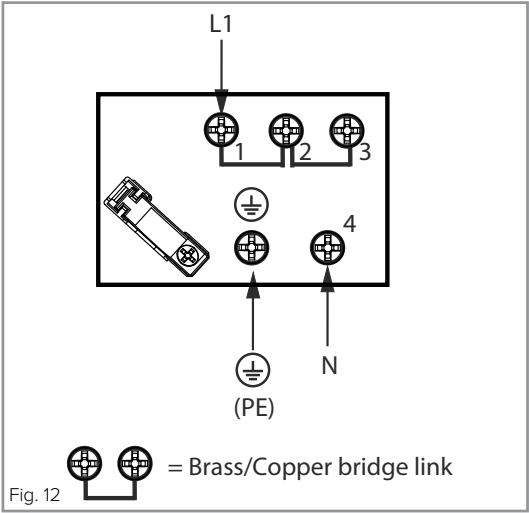

- Ensure that the leads are securely fitted. Failure to do so may prevent the hob from operating correctly.

Appliance electrical rating: 6000W

Energy Efficiency Information

Attribute	Symbol	Value	Units
CDA model		HC6211FR	
Type of hob		Built in	
Number of cooking zones and/or areas		4	
Heating technology (induction cooking zones and cooking areas, radiant cooking zones, solid plates)		Radiant cooking zones	
For circular cooking zones or area: diameter of useful surface area per electric heated cooking zone, rounded to the nearest 5mm	∅	FL:18.0/ FR:14.5/ RL:14.5/ RR:18.0/	cm
For non-circular cooking zones or areas: length and width of useful surface area per electric heated cooking zone or area, rounded to the nearest 5mm	L W	NA	cm
Energy consumption per cooking zone or area calculated per kg	EC <small>Electric cooking</small>	FL:193.5/ FR:193.5/ RL:193.5/ RR:193.5/	Wh/kg
Energy consumption for the hob calculated per kg	EC <small>Electric hob</small>	193.5	Wh/kg

Please contact our **Customer Care Department** for Service on the details below

Customer Care Department

The ICDAI Group Ltd. • Harby Road • Langar • Nottinghamshire • NG13 9HY
T : 01949 862 012 F : 01949 862 003 E : customer.care@cda.eu

