

DIRECTORATE OF ESTATES
PROCEDURE AND INFORMATION MANUAL
EPM GM13 Signage Strategy

Document Originated:	February 2007	By:	Tony Arnott
Issue Number:	1	Number of pages:	105
Approved by EMG:		Status:	Working Document
Last revised:		By:	
Next revision:	February 2008	By:	Development Surveyor

1. Purpose of Document

This document provides guidance on the University standard for external and internal signs to be adopted for all new buildings and alteration/ refurbishment schemes.

Signage Guidelines

Draft Issue September 2006.

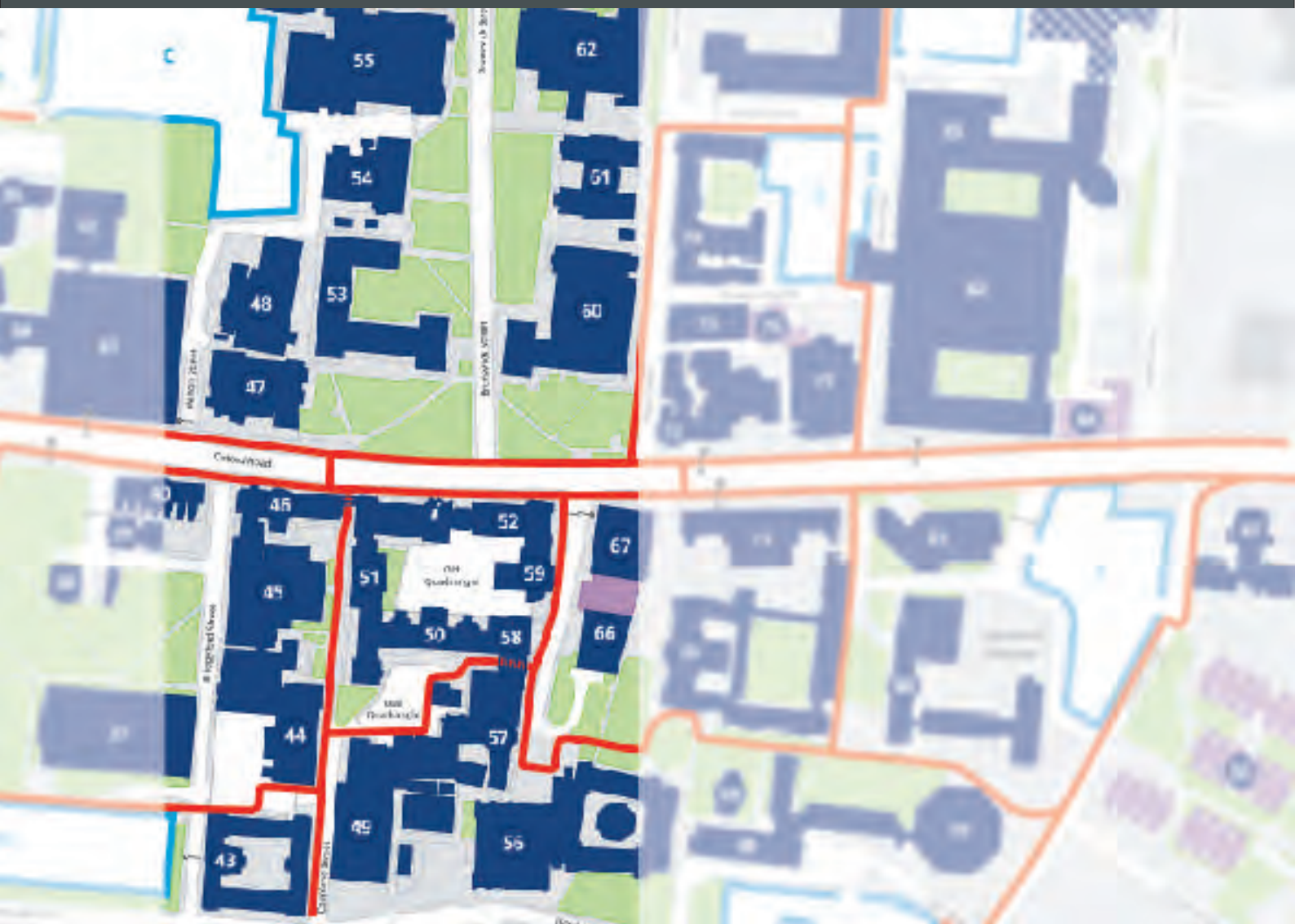

Contents

Introduction

Campus maps

External Signage:

Low Level Signs

Introduction

1.1 University Identification

1.1.1 Gateway Monolith

1.2 Building Identification

Identification Sign Family

1.3 Directional Signs

Directional Sign Family

1.4 Car Park Signs

Car Park Sign Family

1.5 Information Signs

Information Sign Family

High Level

Introduction

2.1 High Level Signs

High Level Images

High Level Sub-brand

3.0 Specification

3.1 Introduction

3.2 Finish

3.3 Graphics

Visual Guidelines

3.4 Monolith Construction (A)

3.5 Monolith Construction (B)

3.6 Tray Sign Construction

3.7 I.T Devices - Security Intercom

High Level Tray Sign (A)

High Level Letters (C)

High Level - Bird Deterrents

3.9 Decorative Base Units - illuminated

- non illuminated

3.10 Fixing to fence and glass

3.11 Plinth attachment

3.12 Electronic messaging board

3.13 Chemical fixing

3.14 Electronic specification

4 Internal Signage:

5 Colours and Logo

5 Colours

5.2 Typography

5.3 Corporate Logo

5.4 Accessibility and the DDA

Introduction



The University of Manchester has teaching and research in more subjects than any other single-site British University. It also has a rich heritage and an exciting agenda for the future.

The campus is located in the heart of Manchester and contains many heritage listed and modern buildings. The campus is split geographically North to South by the Mancunian Way and is dissected by two other key roads into the city.

The University of Manchester's signage programme has three key objectives:

- Identify buildings and subjects within buildings.
- Provide direction and location information to assist visitors, students and local citizens.
- Raise awareness about the geographic location of the campus and the Universities importance as a major institution within the city.

This sign guideline manual sets the standard for a high quality sign package that is intended to raise the profile of the University. It also considers the key objectives listed above and the need to offer inclusive strategies that work for people with disabilities.

The manual is divided into the following sections:

- External
 - External High Level
 - External Low Level
 - Specification
- Internal
 - Internal signs
 - Specification

Order Process |

Please refer to the University's procurement document for general advice.

External Signs

Situation

If you require a replacement sign due to vandalism or damage.

Action

Carry out a physical appraisal of the site to assess which UM code the sign is, and to make sure the text and graphics are still correct.

Assess whether the sign can be repaired by replacing the graphics.

If so, obtain a quotation for the removal, repair and installation of the sign/s from an approved signage contractor.

If not, obtain a quotation for the removal, supply and installation of the sign/s from an approved signage contractor

Situation

If you require a new sign carry out a physical appraisal of the site.

Action

Choose the type of sign required from the design guide.

Choose the wording required for the signs with the scope of the guidelines.

Obtain a quotation for the supply and installation of the sign/s from an approved signage contractor.

If you are unsure of what graphics are on the sign, there is a database of existing signs on this CD in PDF format filed by geographical location e.g. Hardy Farm and by sign type for the larger sites e.g. Main Campus Building ID signs.

Internal Signs

Replacement panels only

Situation

If you require a replacement sign due to text changes, vandalism or damage.

Action

Carry out a physical appraisal of the site to assess which UM code the whole sign is and to make sure the text & graphics are still correct .

Then assess the size of the panel/s that require replacing.

Most of the internal signs can be replaced without installation by a signage contractor therefore seek a quotation for supply only and/or supply and install from an approved contractor

New signs

Situation

If you require a new sign carry out a physical appraisal of the site,

Action

choose the type of sign required from the design guide.

Choose the wording required for the signs with the scope of the guidelines.

Obtain a quotation for the supply and installation of the sign/s from an approved signage contractor

Introduction

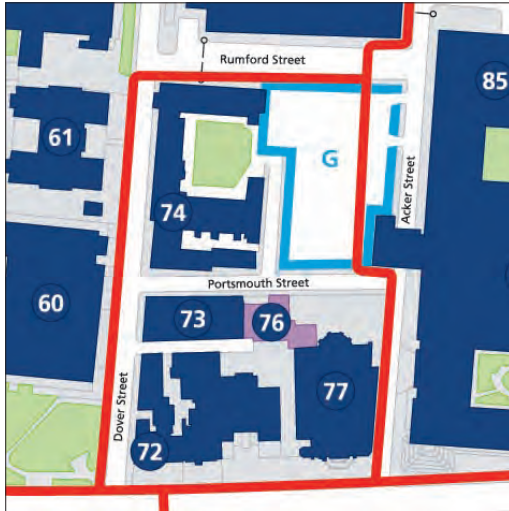

Campus Map

The campus map design is built around a contrasting colour palette (limited to 5-6 colours) with clear images and easily readable text. The map focuses on building names (with numbers) and the buildings are connected via accessible routes through the campus.

Due to the number of building developments planned by the university over the course of the next 10 years the map will be amended on a regular basis. For this reason removable self adhesive vinyl digital prints are the preferred method for this item.

Structure & Graphic Content of all the Signs

To withstand the City environment, new low level signs have been designed to be very robust:

- Monolith type signs are to be made from 3mm aluminium covers and steel sub frames.
- Tray signs are to be made from 3mm aluminium with aluminium angle fixings
- They are to be painted and over laquered with graffiti and UV resistant materials

| External Signs

No external signs should be specified or procured without prior written consent from the Directorate of Estates.

Extended Sign Family

All low level signs are visually linked to one another using similar materials and graphic devices. This family is meant to evolve and be extended sympathetically overtime. It is divided into the following initial sign types:

- 1- University Identification
- 2- Building Identification
- 3- Campus Information
- 4- Directional Signs
- 5- Car Parks
- 6- Street Names

Manufacture & Installation

A majority of low level signs comprise of monolithic structures both double and single sided. The location of some units mean that they require decorative base surrounds as well as secure foundations. Some monolithic structures also require uplighters.

1.1 | University Identification

The following pages show preferred sign types for university identification signs.

These are described with a code name and number:

1.1.1 Gateway monolith UM01

1.1.1 | University Identification

Gateway Monolith UM01



Example only

To be used primarily to identify key vehicular routes into the campus to raise the University profile to visitors.

This page shows the positioning appropriate to this sign type.

Preferred position is facing a mainroad that leads onto the campus.

The signs will be illuminated at night by floor mounted ground flood lights, see (section 3 specification)

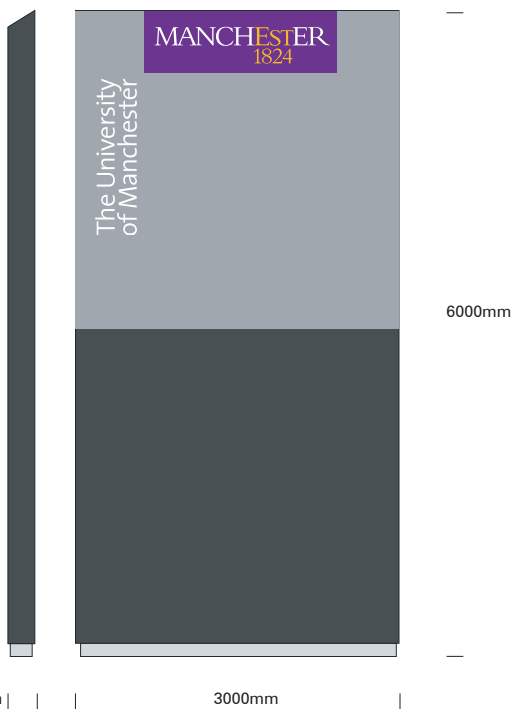

Sizes for UM01

Width	Height	Depth
3000mm	6000mm	250mm

1.2 | Building Identification

The following pages show preferred sign types for Building Identification signs.

These are described with a code name and number and application principle

1.2.1 Building Name monolith UM02

1.2.2 Building Name wallmounted UM03

1.2.5 Sub Brand monolith UM04

1.2.5 Sub Brand wallmounted UM05

1.2.6 Post and Panel UM06

1.2.1 | Building Identification

Building Name monolith UM02

To be used to identify the building title.

This page shows the positioning appropriate to this sign type.

Building name monolith signs located in grassed area's require decorative base surround non illuminated type A,
(See section 3 specification)

Graphics
Type height
40mm TheSans SemiBold

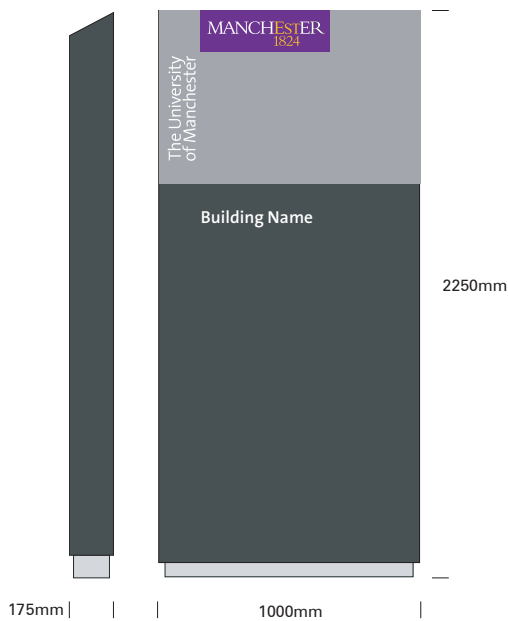

Sizes for UM02	Width	Height	Depth
This sign type has one size	1000mm	2250mm	175mm

1.2.1 | Building Identification

Building/Site Name Post & Panel sign UM06

To be used to identify the building/site title where there is no suitable wall space and where there is an obstacle such as a fence or low wall which would obscure a monolith.

Preferred location is directly adjacent to the entrance of a site.



Graphics
Type height
40mm TheSans SemiBold

Sizes for UM02	Width	Height	Depth
This sign type has one size	2000mm	1000mm	175mm

1.2.2 | Building Identification

Building Name wall mounted UM03

To be used to identify the building title.

This page shows the positioning appropriate to this sign type.

Preferred position is directly adjacent to the entrance of a building, with the top of the sign aligned to an architectural building feature.

Graphics
 Type height 30/40*/50mm
 TheSans SemiBold

Text height is dependent on the panel size



Sizes for UM03	Width	Height	Depth
This sign type has four recommended sign sizes	450mm	450mm	20mm
	600mm	600mm	30mm
	700mm*	700mm*	30mm*
*Preferred size whenever possible	900mm	900mm	30mm

1.2.5 | Building Identification

Sub Brand monolith UM04



To be used primarily to identify the building title, but also raise the profile of the building to visitors.

This page shows the positioning appropriate to this monolithic sign type. An alternative is a tray sign wall mounted (see below).

Preferred position is directly adjacent to the main entrance, perpendicular to the pavement.

Graphics
Type height 34/40mm TheSans SemiBold

For the Sub-brand logo options, see The University of Manchester Corporate Design Guidelines, available from Public Relations.

Sub Brand wall mounted UM05

Preferred position is directly adjacent to the entrance of the subject area, with the top of the sign aligned to the top of the door where possible.

Graphics
Type height 15/17/34*/40*mm TheSans SemiBold

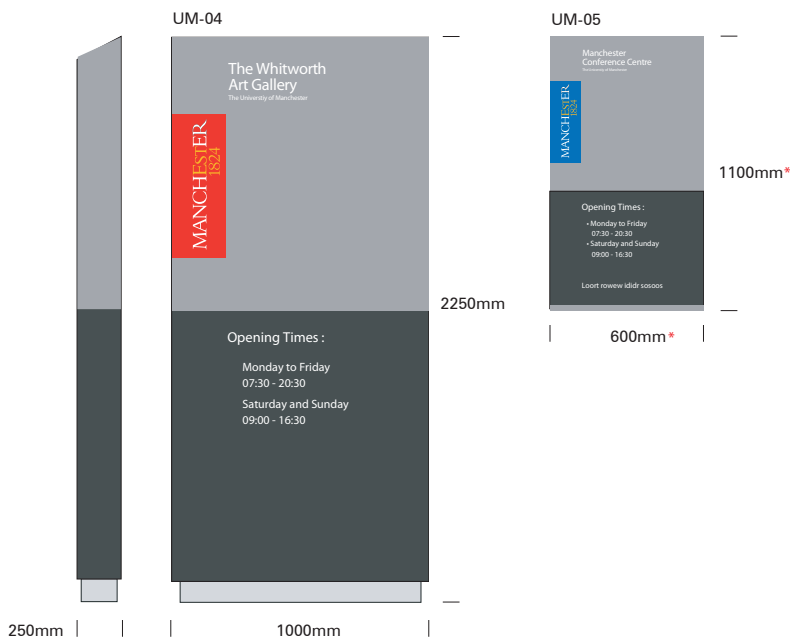

Sizes for UM04	Width	Height	Depth
This sign type has two sizes	1000mm	2250mm	175mm
	1200mm	4250mm	175mm

Sizes for UM05	Width	Height	Depth
This sign type has two recommended sign sizes	600mm*	1100mm*	30mm
	400mm	740mm	30mm

*Preferred size whenever possible

1.3 | Directional Signs

Overview

The following pages show the different sign types for Directional signs. These sign types are designed to be used at street-level to direct users to buildings and centres within the University; whether they travel by foot or by road.

They are to be located on or around major pedestrian routes through the campus.

The following signs types are included in Directional Signs. These are described with a code, name and application principle.

UM07 Pedestrian Directional Monolith provides directions for pedestrian users at main decision points.

UM-08 Pedestrian / Vehicular Directional Monolith provides directions for vehicular users on one side and pedestrian users on the other.

UM-09 Vehicular Monolith provides directions for service delivery vehicles off the main roads into the campus.

UM-10 Street Name post mounted

UM-11 Street Name wall mounted

UM-11b Street Name wall mounted

1.3 | Directional Signs

The following pages show preferred sign types for Directional signs.

These are described with a code name and number:

- 1.3.1 Pedestrian Directional monolith UM07
- 1.3.2 Pedestrian / Vehicular Directional UM08
- 1.3.3 Vehicular Directional UM09
- 1.3.4 Wall mounted directional UM10
- 1.3.5 Street Name post mounted UM11
- 1.3.6 Street Name wall mounted UM11b

1.3.1 | Directional Signs

Pedestrian directional monolith UM07



This page shows the positioning appropriate to this sign type.

Preferred position's are on footpaths, or where footpaths intersect and along designated accessible routes. Corporate branding on one or both sides.

Graphics
 Type height
 40mm TheSans SemiBold
 Arrow size
 74 x 57mm

Symbol
 120mm high

Hierarchy of information
 Left precedence arrows first then text and other arrows in hierarchical order.

Note:
 The Accessible Route graphics should only be used when the sign is positioned along an accessible route.

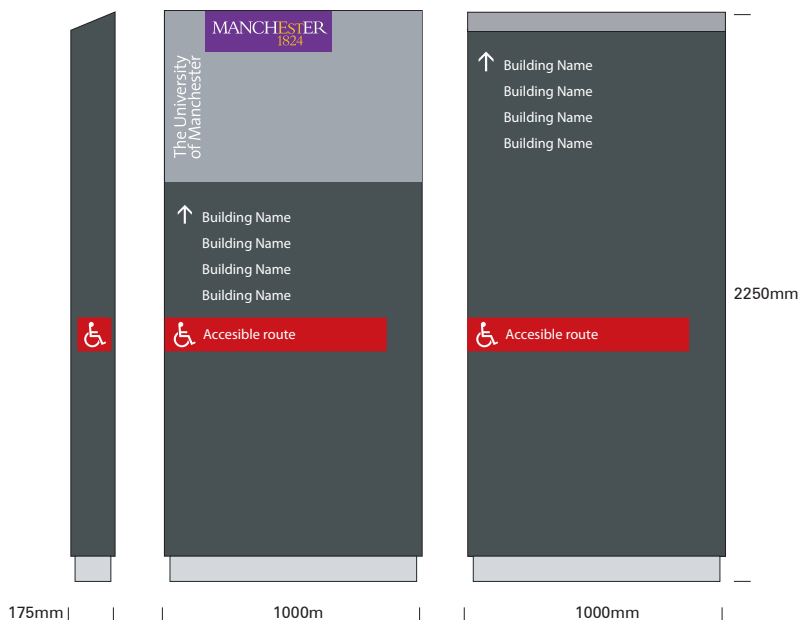

Sizes for UM08	Width	Height	Depth
This sign type has one size	1000mm	2250mm	175mm

1.3.2 | Directional Signs

Pedestrian Directional/ Vehicular Directional Monolith UM08

Preferred position is at road sides where both vehicular and pedestrian information is required, symbols are used on the facing side panel to alert goods vehicles to the access route for deliveries.
Corporate branding on one or both sides.

Graphics

Type height 50mm TheSans SemiBold
Arrow size 74 x 57mm

Hierarchy of information

Left precedence arrows first then text and arrows in hierarchical order.

Symbols

Symbols are positioned on the side of the monolith and are arranged vertically (allows up to 3 pictograms).
Height of symbols 120mm.

Note:

The Accessible Route graphics should only be used when the sign is positioned along an accessible route.

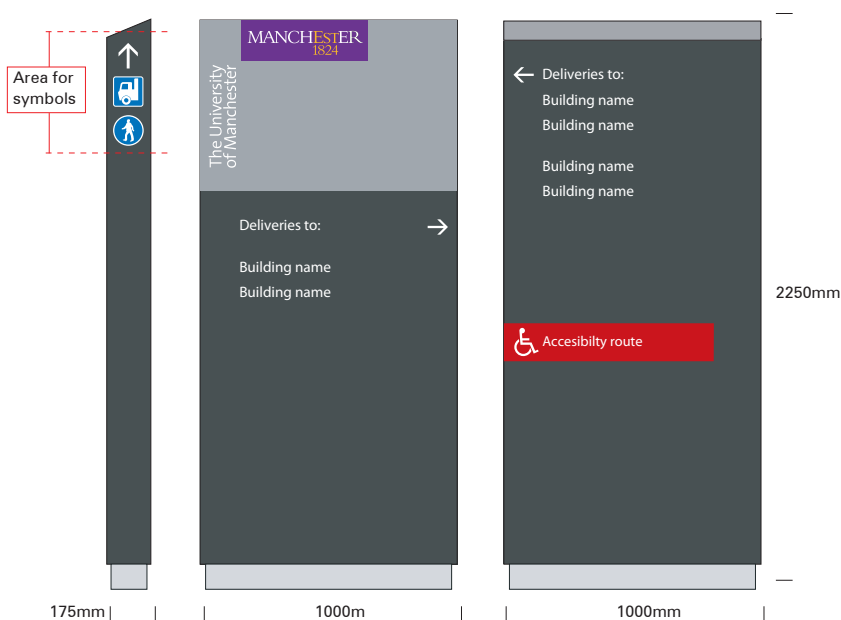

Sizes for UM08	Width	Height	Depth
This sign type has one size	1000mm	2250mm	175mm

1.3.3 | Directional Signs

Vehicular Directional Monolith UM09

Preferred position is at road side, symbols are used on the facing side panel to alert goods vehicles to the access route for deliveries.

Corporate branding on one or both sides.

Graphics

Type height 50mm TheSans SemiBold

Arrow size 74 x 57mm

Hierarchy of information

Left precedence arrows first then text and arrows in hierarchical order.

Symbols

Symbols are positioned on the side of the monolith and are arranged vertically (allows up to 3 pictograms).

Height of symbols 120mm.

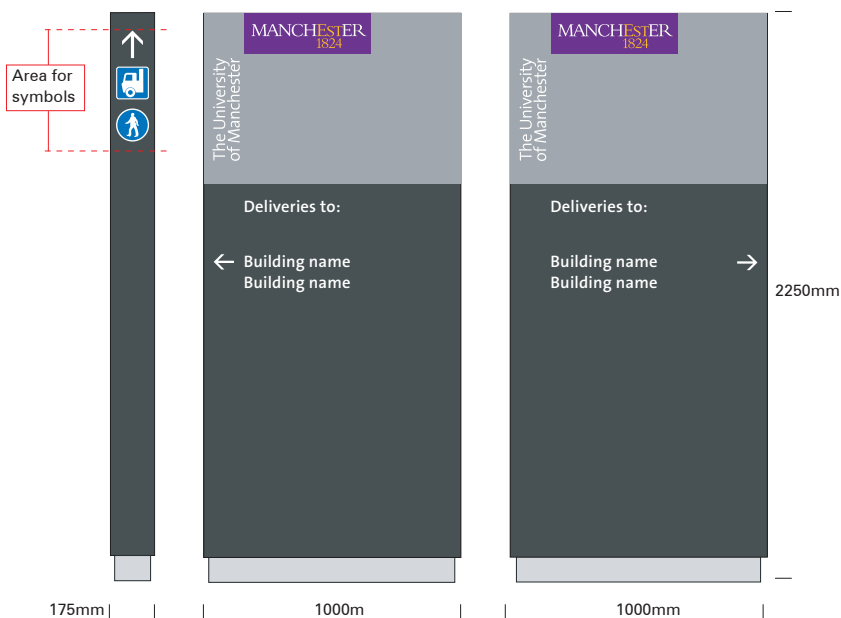

Sizes for UM09	Width	Height	Depth
This sign type has one size	1000mm	2250mm	175mm

1.3.4 | Directional Signs

Wall Mounted Directional Sign UM10

The preferred use for this sign is where a directional monolith can not be used in the first instance

Graphics

Type height 40mm The Sans SemiBold

Arrow size 74 x 57mm

Symbol size 120mm high

Hierarchy of information

Left precedence arrows first then text and arrows in hierarchical order.

Note:

The Accessible Route graphics should only be used when the sign is positioned along an accessible route.

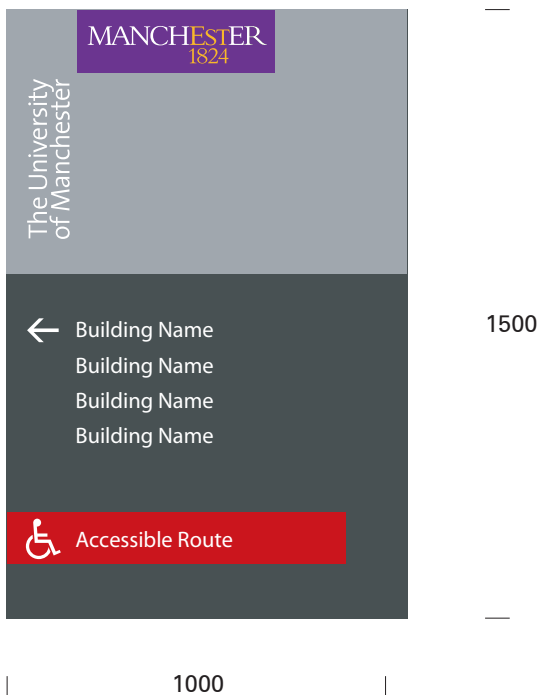

Sizes for UM11b	Width	Height	Depth
This sign type can have other variable signs to suit individual locations	1000mm	1500mm	30mm
	500mm	750mm	20mm

1.3.5 | Directional Signs

Street Name Post Mounted UM11



This page shows the positioning appropriate to this sign type. This sign type can be either single or double sided.

Preferred position is at the start or at a turning into the street.

Graphic
Type height
75mm Aldine 401 BT (Alt)

Note:
Only streets under ownership of the University should be signed in this way. Please check with Directorate of Estates.

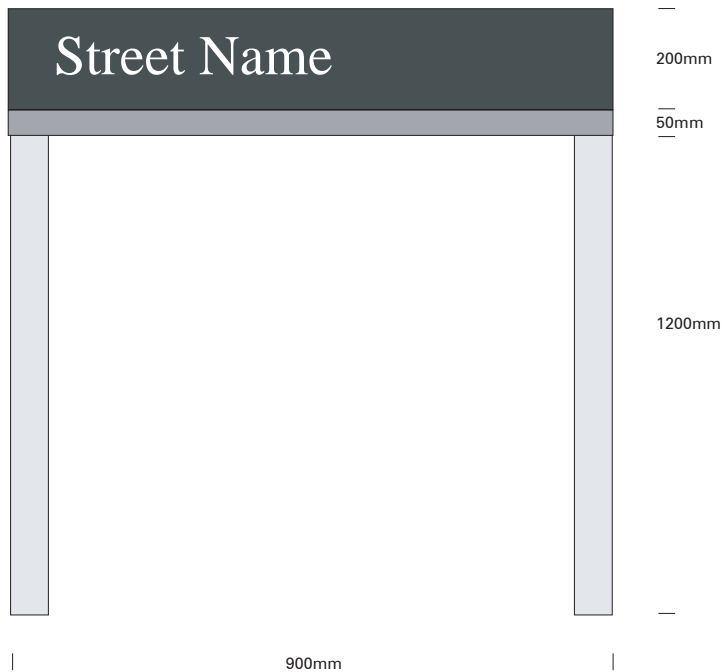

Sizes for UM10	Width	Height
This sign type has one size	900mm	1200mm

1.3.6 | Directional signs

Street Name, Wall Mounted UM11b



This page shows the positioning appropriate to this sign type.

Preferred position is at the start/end or at a turning into the street. Preferred height is 1750mm from ground.

Graphics

Type height 75mm Aldine 401 BT (Alt)

Note:

Only streets under ownership of the University should be signed in this way. Please check with Directorate of Estates.

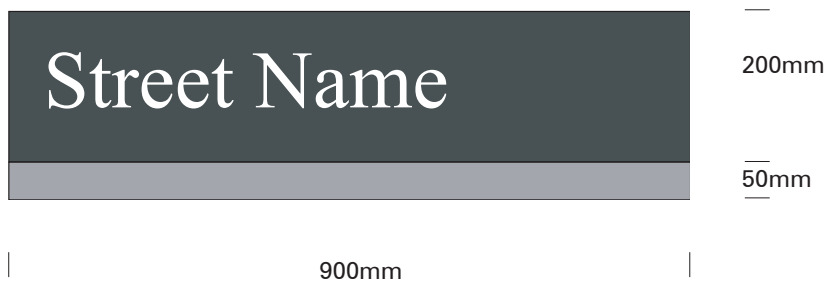

Sizes for UM-11	Width	Height	Depth
This sign type has one size	900	250	

1.4 | Car park Signs

Overview

The following pages show the preferred types of Car Park Signs. The signs contain directional, locational and statutory messages.

These sign types should always display messages accompanied by symbols for easy recognition.

Signs which combine locally relevant symbols (eg. Clamping, Accessible Parking etc.) are preferred to individual signs wherever possible.

The following sign types are included in CarPark Signs. These are described with a code, name and number:

- 1.4.1 Car Park Directional Monolith UM12
- 1.4.2 Car Park Entrance Monolith UM13
- 1.4.3 Car Park Entrance Post & Panel UM14
- 1.4.3 Car Park Entrance Post & Panel UM14b
- 1.4.4 Car Park Entrance Mini Monolith UM15

1.4.1 | Car Park signs

Car Park Directional Monolith UM12 (single or double sided)

Preferred position is adjacent to main roads to direct vehicles to University car parks. Corporate branding on one or both sides.

Graphics

Type height 50mm TheSans Bold
Arrow size 57 x 74mm

Hierarchy of information

left precedence arrows first then text in hierarchical order.

Symbols

Symbols are positioned on the side of the monolith and are arranged vertically, allows up to 3 pictograms. Height of symbols 120mm

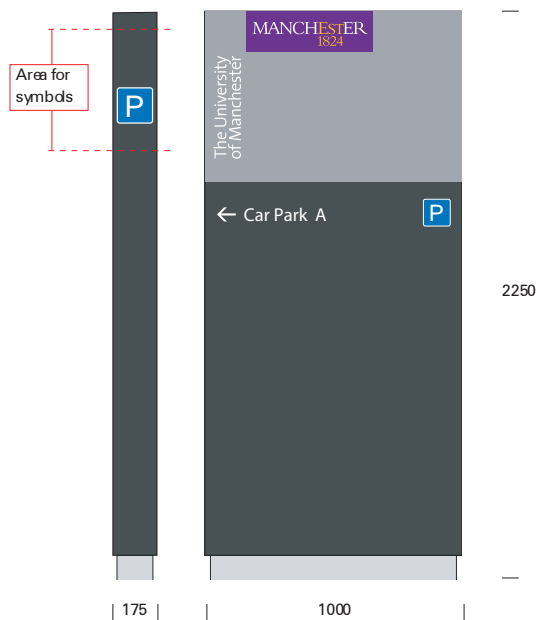

Sizes for UM-2	Width	Height	Depth
This sign type has one size	1000	2250	175

1.4.2 | Car Park Signs

Car Park Entrance Monolith UM13

This page shows the positioning appropriate to this sign type.

Preferred position is adjacent to car park barrier entrance. These signs are used to identify the car park, display opening times, parking charges and other information relevant to the specified car park. Information to be on one side only.



Example location only

Graphics

Header information 50mm TheSans Bold,
Secondary information 40mm TheSans SemiBold

Symbols

Symbols are positioned on the side of the monolith and are arranged vertically, allows up to 3 pictograms.
Height of symbols 120mm

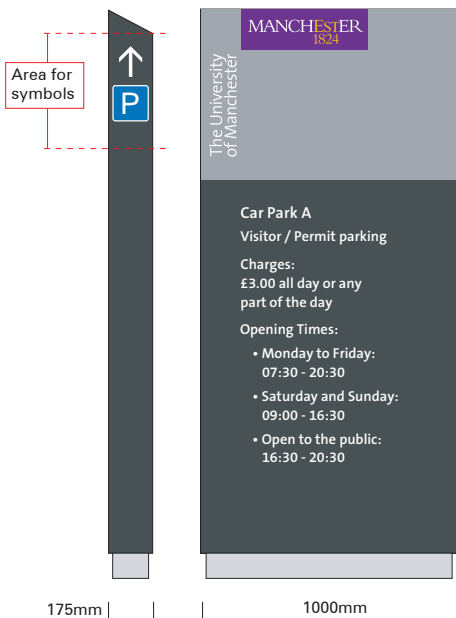

Sizes for UM13	Width	Height	Depth
This sign type has one size	1000mm	2250mm	175mm

1.4.3 | Car Park Signs

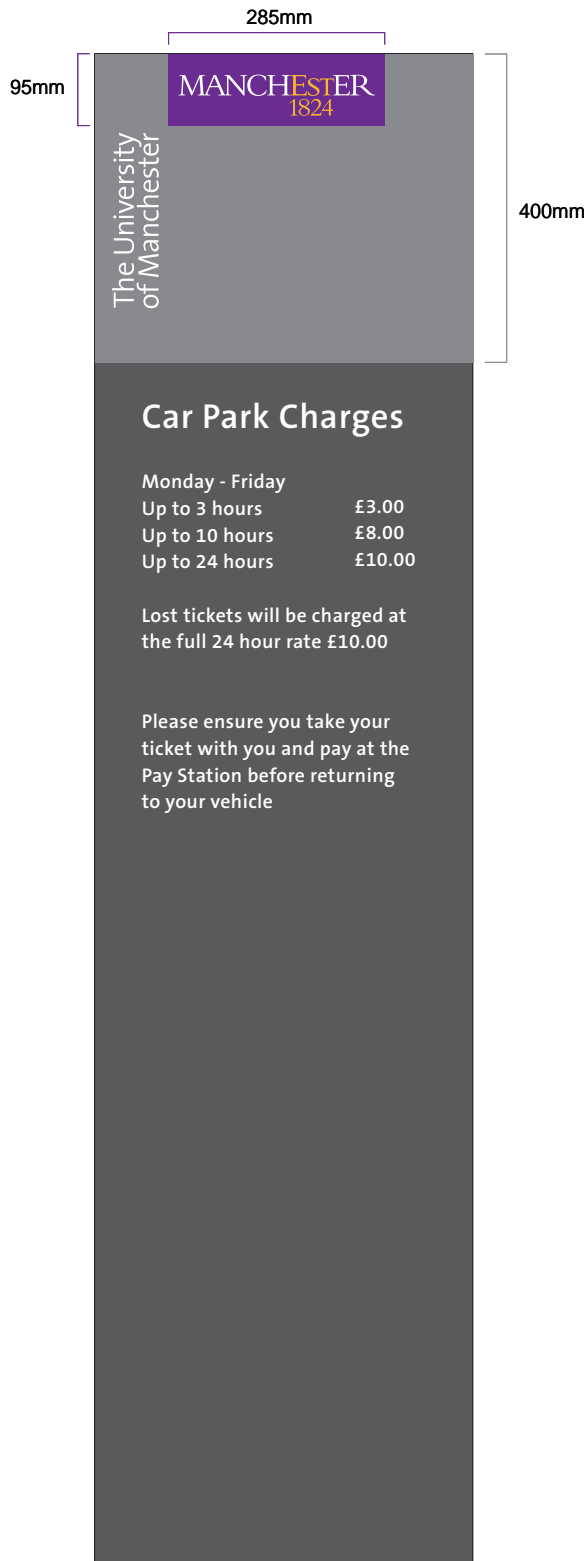

Car Park Entrance Post & Panel UM14

This page shows the positioning appropriate to this sign type.

Graphics
 Header information 40mm TheSans Bold,
 Secondary information 50mm TheSans SemiBold

Symbols
 Symbols are positioned on the side of the monolith and are arranged vertically, allows up to 3 pictograms.
 Height of symbols 120mm

Sign is fixed to a post.

UM14b



Sizes for UM11b	Width	Height	Depth
This sign type can have other	500	1800	30
variable signs to suit individual locations	500	1000	20

1.4.4 | Car Park Signs

Car Park Entrance Mini Monolith UM15

This sign should be used in front of the barriers and so not to obstruct visibility of vehicles. And/or where space restrictions prevail.

This page shows the positioning appropriate to this sign type.

Graphics

Header information 50mm TheSans Bold,
Secondary information 40mm TheSans
SemiBold

Symbols

Symbols are positioned on the side of the monolith and are arranged vertically, allows up to 3 pictograms.
Height of symbols 120mm

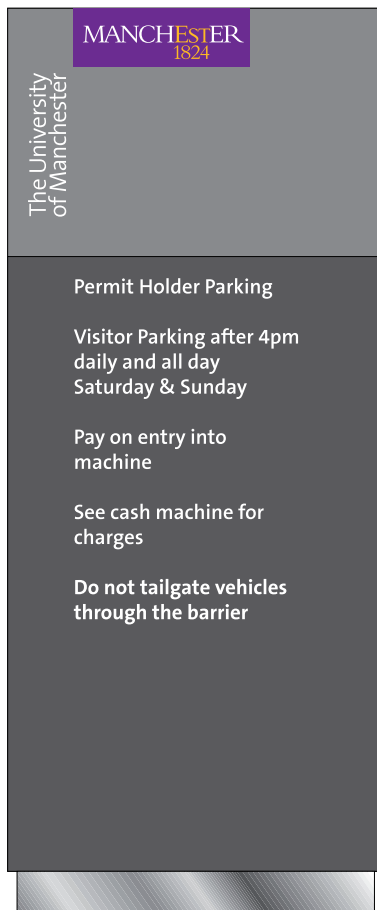

Sizes for UM13b	Width	Height	Depth
This sign type has one size	500mm	1200mm	175mm

1.5 | Information Signs

Overview

The following pages show the preferred sign types for Information Signs. The sign types are designed to be used at street-level. They contain campus maps, directions and general information that familiarise the user with the environment.

These are to be located at directional decision points where there is a large volume of pedestrian traffic and space to stop and read.

The following sign types are included in Information signs. These are described with a code, name and number:

- 1.5.1 Hot Spot UM17
- 1.5.2 Campus Map UM18A Original design
UM18B Preferred method
UM18C Fallowfield design only
- 1.5.3 Campus Map Wall Mounted Tray UM19
- 1.5.4 Conference sign UM20
- 1.5.5 Post mounted postercase UM21
Wall mounted postercase UM21b
- 1.5.6 Precinct sign UMPC01

1.5.1 | Information Signs

Hot Spot Monolith (Double sided) UM17 with security intercom and induction loop

This page shows the positioning appropriate to this sign type.

Preferred position is at locations determined as major thoroughfare or meeting points within the campus

Hot spot signs include directions, campus map and general information help to orientate and familiarise the user with their surroundings (see campus map orientation page to establish correct orientation of maps to each side of the sign)

Security Intercom Device

Mounted into the monolith structure is a Security Intercom Device. This comprises of a tactile 'call' button to comply with the Disability Act and an induction Loop Facility connected to the audio device, in order to amplify sound for the hard of hearing.

Hard wiring from Monolith onto the University telephone network to be provided by the University and telephone interface within the security office to be supplied with the Audio Entry Device.

See campus map orientation options to establish the correct orientation at each location.

Graphics

Type Height 40/50mm The Sans SemiBold

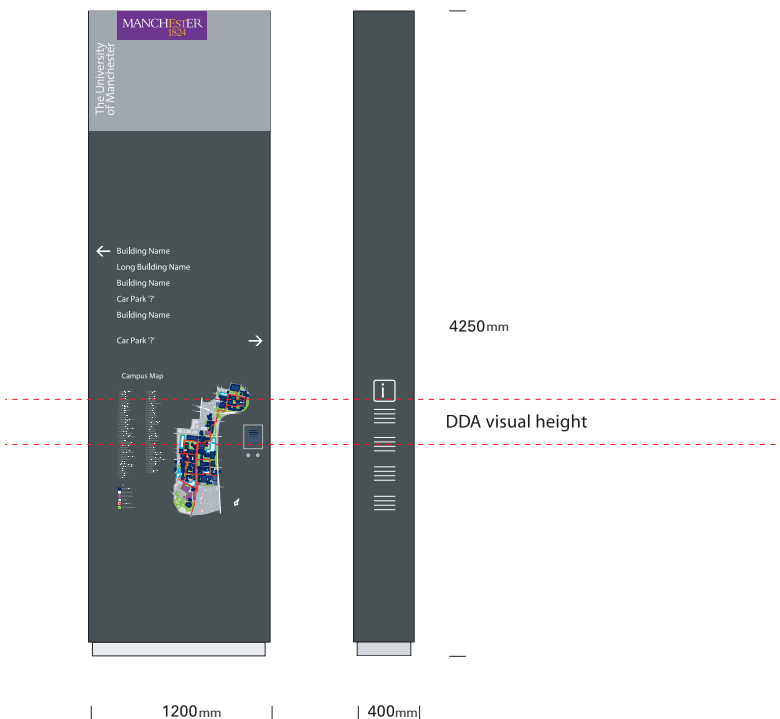

Sizes for UM-17	Width	Height	Depth
These sign types have one size	1200mm	4250mm	400mm

See Specification section at back of manual for security intercom specification.

1.5.2 | Information Signs

Original Camp Map Monolith Design UM18 With or without intercom device.

This Design should no longer be used, refer to UM18B. This option should only be used for replacement purposes.

This page shows the positioning appropriate to this type of sign.

Preferred position is at locations near to car parks and locations determined as major pedestrian access routes.

A plinth detail is provided in the Specification pages at the end of the report, but not all campus maps will require a plinth.



Sample location only

Security Intercom Device

Where fitted, mounted into the monolith structure is a Security Intercom Device. This comprises of a tactile 'call' button to comply with the Disability Act and an induction Loop Facility connected to the audio device, in order to amplify sound for the hard of hearing.

Hard wiring from Monolith onto the University telephone network to be provided by the University and telephone interface within the security office to be supplied with the Audio Entry Device.

See campus map orientation options to establish the correct orientation at each location.

Graphics

Type Height 40/50mm The Sans SemiBold
Key 8mm

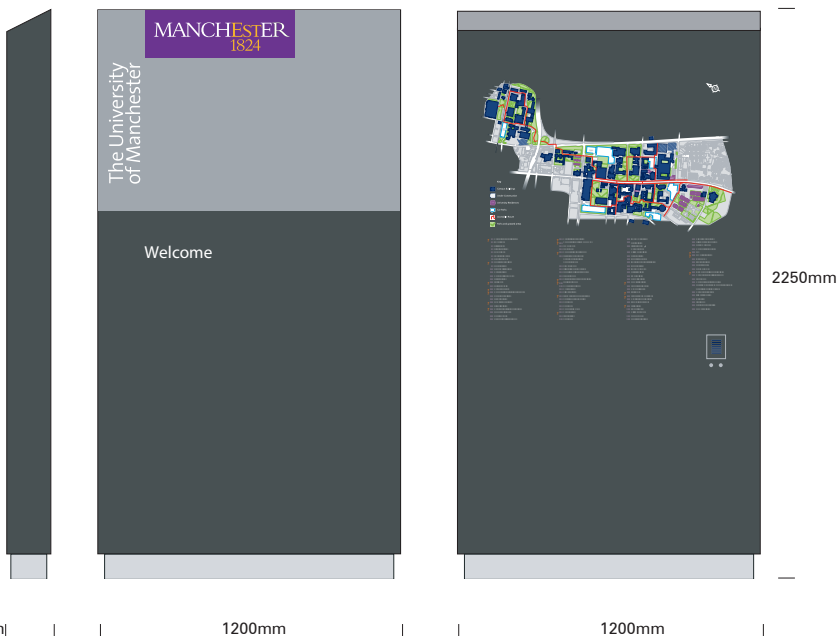

Sizes for UM-18	Width	Height	Depth
This sign type has one size	1200mm	2250mm	175mm

1.5.2 | Information Signs

Campus Map Monolith UM18B

This page shows the positioning appropriate to this type of sign.

Preferred position is at locations near to car parks and locations determined as major pedestrian access routes.

A plinth detail is provided in the Specification pages at the end of the report.

Security Intercom Device - Where fitted
Mounted into the monolith structure is a Security Intercom Device. This comprises of a tactile 'call' button to comply with the Disability Act and an induction Loop Facility connected to the audio device, in order to amplify sound for the hard of hearing.

Hard wiring from Monolith onto the University telephone network to be provided by the University but telephone interface within the security office to be supplied with the Audio Entry Device.

See campus map orientation options to establish the correct orientation at each location.

Graphics
Type Height 40/50mm The Sans SemiBold
Key 8mm

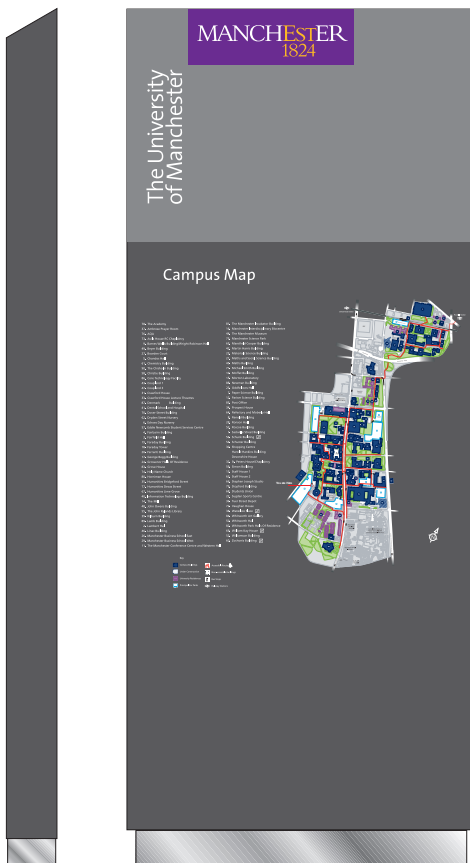

Sizes for UM-18	Width	Height	Depth
This sign type has one size	1200mm	2150mm	175mm

Fallowfield Campus



Campus Map Monolith UM18C

Preferred position is at locations near to car parks and locations determined as major pedestrian access routes.

A plinth detail is provided in the Specification pages at the end of the report.
When installing new campus map monoliths sign UM 18b is the preferred type

Graphics
Type Height 40/50mm The Sans SemiBold
Key 8mm

Sizes for UM-18C	Width	Height	Depth
This sign type has one size	1200mm	2200mm	175mm

1.5.3 | Information Signs

Campus Map Wall Mounted Tray UM19



Sample location only

This page shows the positioning appropriate to this type of sign.

Preferred position is at locations near to car parks and locations determined as major pedestrian access routes within the campus boundary.

See campus map orientation options to establish the correct orientation at each location.

Graphics
Type Height 40mm The Sans SemiBold
Key 8mm

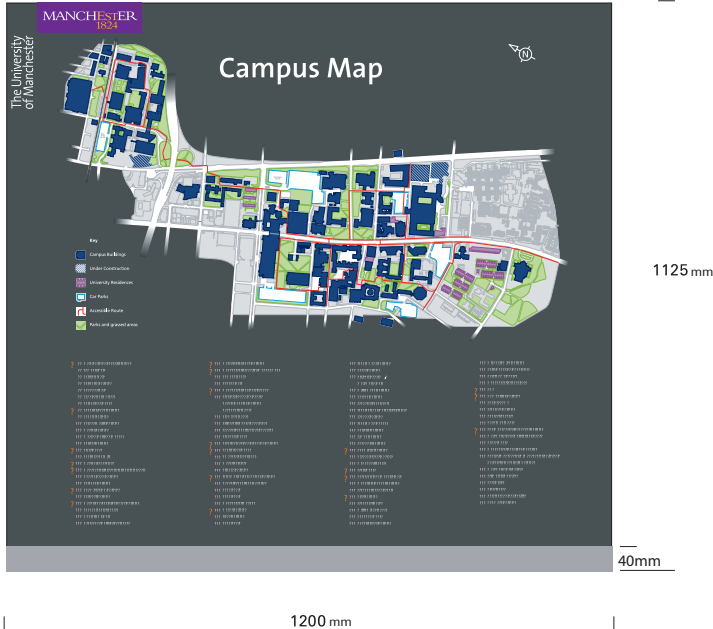

Sizes for UM-19	Width	Height	Depth
This sign type has one size	1200 mm	1125 mm	30 mm

1.5.6 | Information Signs



External sign to Precinct Centre (existing sign)

Precinct Centre Monolith UMPC-01

This sign to be located at the external access to Precinct Centre.

Free standing identification sign, construction as standard University of Manchester pedestrian directional monolith construction specification finished to University corporate colours.

With MSS/Classic Directory 40no. P90 profiles x 1500mm wide, University corporate colour Grey RAL 7015 screenprinted White.

Graphics

Header panel to be as per the internal signage of the precinct centre but also to include the University logo.

Type

40mm high TheSans SemiBold
50mm high header TheSans Bold

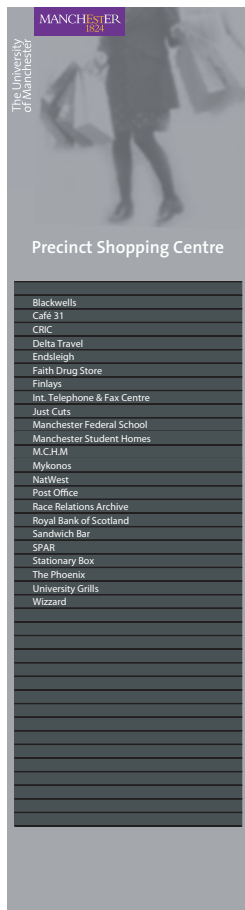

Sizes for UMPC-01	Width	Height	Depth
This sign type has one size	1600mm	6000mm	200mm

1.5.7 | Internal Signs

Wall Mounted Commemorative Plaque UM45

Wall mounted panel, comprising 316 grade satin stainless steel plate, square corners, finished edges. Face of panel to be chemically etched, with text infilled black, logo style infilled purple, yellow, white as appropriate.

Panel flush inlaid into a hardwood backpanel.

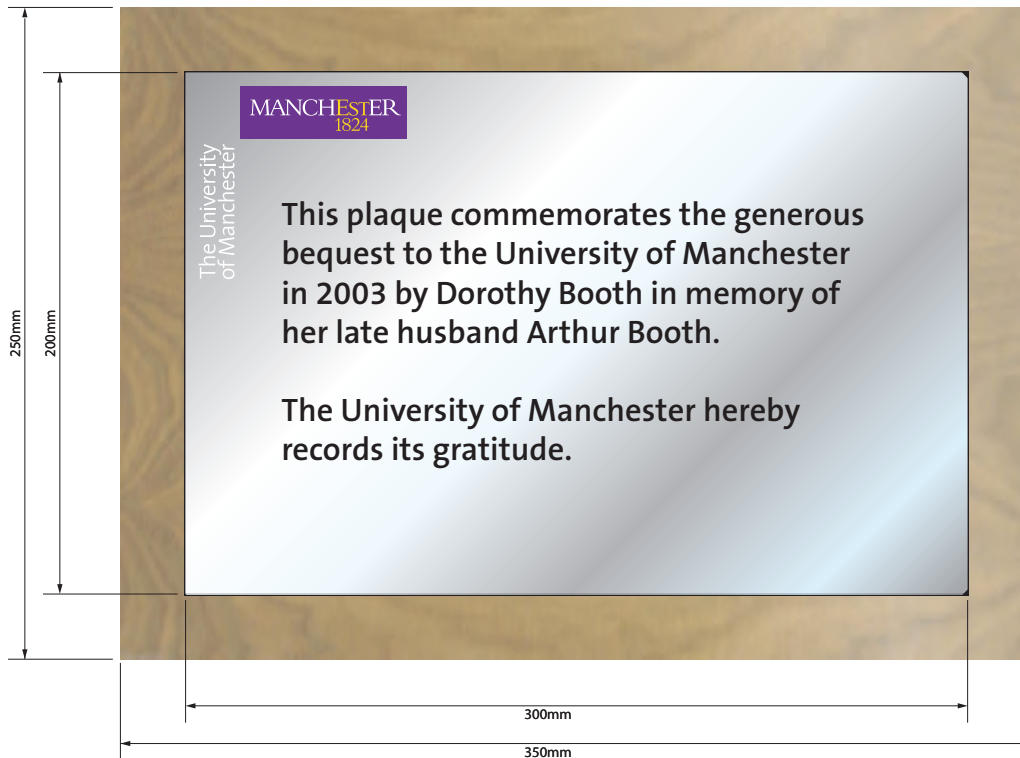

1.5.8 | Exterior Signage

External Grade Postercase
Post mounted UM21
Wall mounted UM21b



Martin Harris Centre for Music & Drama

To be used when numerous temporary messages are to be displayed
Can be post mounted or wall mounted

External Colour – Dark Corporate Grey
Pinboard Dark Grey

Graphics
40mm high The Sans centred

Fixing
Screw fixed or post mounted

This sign should not be specified or procured without prior written consent from the Directorate of Estates.



External Signs

Section 2 | High Level Signs

Overview

Locations

The following pages show the position of all High Level Signs. These are to be manufactured and installed at high level onto selected building fascias in order to increase the Universities profile around the City of Manchester.

Locations have been selected in discussion with the City Planners and are primarily positioned onto buildings that align with the road, rail, bus and pedestrian routes into the campus.

Structure and graphic content comprises of painted trays with shallow built up letters. Tray signs to have screen printed detail and are mounted flush to walls.

Letters are stood off from walls using bespoke male/female stainless steel locators (see specification pages and use in conjunction with itemised photographs and "HighLevel" campus plans).

Initial Sign types are therefore:

2.1.1 High Level Brand Image UM-22

2.1.2 High Level Built Up Letters UM-23

Note:

No high level signs should be specified or purchased without prior written consent from the Directorate of Estates.

2.1.1 | High Level Signs

High Level Brand Image UM-22



This page shows the positioning appropriate to this sign type.

Preferred position is on the prominent face of considered buildings that line road/railway/bus/pedestrian routes into campus.

The logo should always be positioned in the left hand corner of the selected building face. To be used primarily onto University buildings at high level in order to raise the University profile to visitors.

Note: Spacing of the white vertical text has been extended on the High Level signs.

A certain number are externally illuminated, please refer to plan.



Sizes for UM-22	Width	Height	Depth
The size of this sign will depend upon height of building and available space.	-	-	-

2.1.2 | High Level Signs

Built Up Lettering UM-23



This page shows the positioning appropriate to this sign type.

Preferred position is fixed to a bridge parapet.

Refer to specification pages for details of the built up lettering.

Note: Where required individual letters can be chemically fixed with rear stud fixings

The surface to be fixed to should be predrilled ready to receive the mechanical fixings and any loose debris removed.

Fill the space with chemical adhesive. The mechanical fixings should be inserted into the filled space. These should then be physically or mechanically held until the adhesive has suitably set to hold/support the fixings and the sign.

All chemical fixings should be carried out in line with adhesive manufacturer's instructions

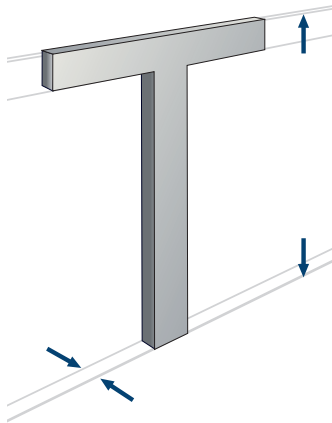

The University of Manchester

Sizes for UM-23	Width	Height	Depth
	-	600	32

2.1.3 | High Level Sub Brand Signs

Sub Brand High Level UM-22/b



Preferred position refer to next page for locations.

The colour portion of the logo should always be aligned with the corner of a building. Where this is not possible the logo should be aligned with an architectural feature of the building such as a vertical sequence of windows or coloured brickwork.

The dimensions of 'X' and 'Y' should be determined by a site visit, taking into account the available space and height from ground level.

The principles outlined above should be applied equally to other Sub Brand sites.

Sizes for UM-05/b	Width	Height	Depth
This sign type has one size	X	Y	

Section 3 | Specification Introduction

External signs

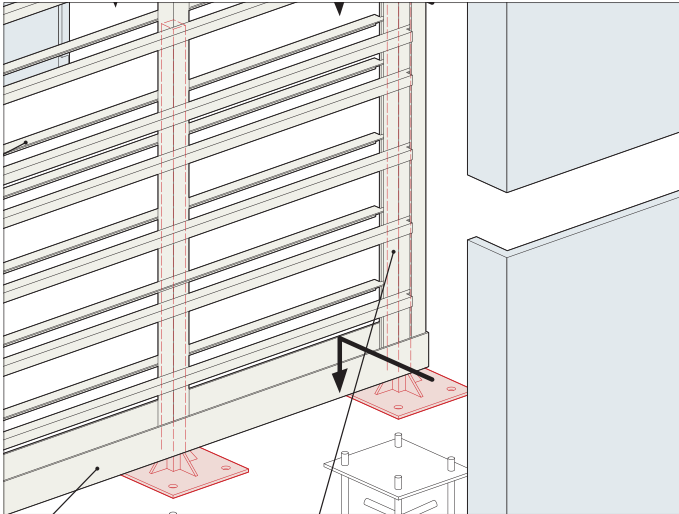

The following pages detail sign construction materials, sizes, colours etc. for both low and high level signs. Any deviation from these specifications must, in the first instance, be detailed by the sign manufacturer and submitted in writing to the Universities Supervising Officer nominated for signage, who at this time is Mr T Arnott (T: 0161 275 7525).

External sign

3.1 | Finish specification

Sign components are to be spray-painted all round using a two pack acrylic, laquerpaint system with Isocyanate hardeners. The recommended paint supplier is: ICI Paints, Needham Road, Stourmarket, Suffolk, IP14 2AD (or equal and approved)

All sign surfaces including front, side edges and rear surfaces must be carefully prepared and etch primed using a chromate free, 2 pack etching primer. Only this recommended etch primer will be acceptable. Then apply three layers of high build top coat using ICI 2K MS paint system (or equal and approved) in a one stage process and then bake at a temperature of 60°C in a full bake oven. Finally, once text and graphics have been screen-printed onto the painted surface, finish by applying two coats of graffiti resistant clear, 100% automotive gloss lacquer. The lacquer is an important final stage in sealing and protecting against long term airborne contamination and stone chipping, ensuring that all signs look more pristine over a longer period of time and are protected from UV degradation and colour fade. To avoid surface dust contamination and orange peel effects an automotive sprayshop, full bake facility should be employed for the spraying of all sign components.

3.2 | Graphics Specification



For optimum performance (appearance and security), graphics will be screen-printed using a solid opaque two pack exterior quality ink through a 90T mesh, with artwork being produced at a minimum of 1200 dpi.

Symbols

A family of symbols have been developed for use on external signs. The range of symbols are listed below and illustrated here:

- 1 Parking
- 2 Bicycles allowed
- 3 Pedestrian area
- 4 Disabled Access
- 5 Bus Route
- 6 Security Camera
- 7 Wheelclamp
- 8 Accessible Parking
- 9 Information
- 10 Deliveries

3.3 | Monolith Construction (A)

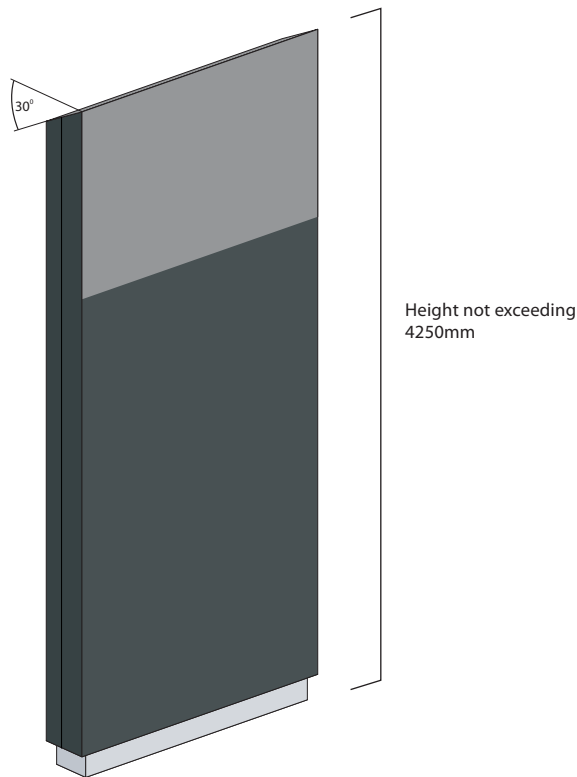

Specification principals for all low level monolithic signs upto an overall height of 4250mm to be read in conjunction with the exploded view drawings on the following page.

The front and back panels are to be fabricated out of 3mm aluminium panels. Blanks are to be cut out and folded to shape. The folded corners are to be fillet welded and dressed. See drawing attached for exact specifications and note that the cross beams prevent the front face from denting inwards and stop the unit from twisting.

Posts to be cast into a concrete base (3 parts 19mm chippings, 2 parts coarse sand, 1 part cement) onsite into a pre-dug hole that has a minimum clearance of 250mm all round each post. Same sign in soft ground may require substantial foundations (building name monoliths and others) the university to be consulted prior to manufacture commencing.

Accurate manufacture of all monolithic structures to a tolerance of ± 1 mm is essential to ensure that front or rear panel sections of any monolith are interchangeable with any unit of a similar size at a later date.

Plinth should be constructed from brushed stainless steel with secret fixings.

3.4 | Monolith Construction (B)

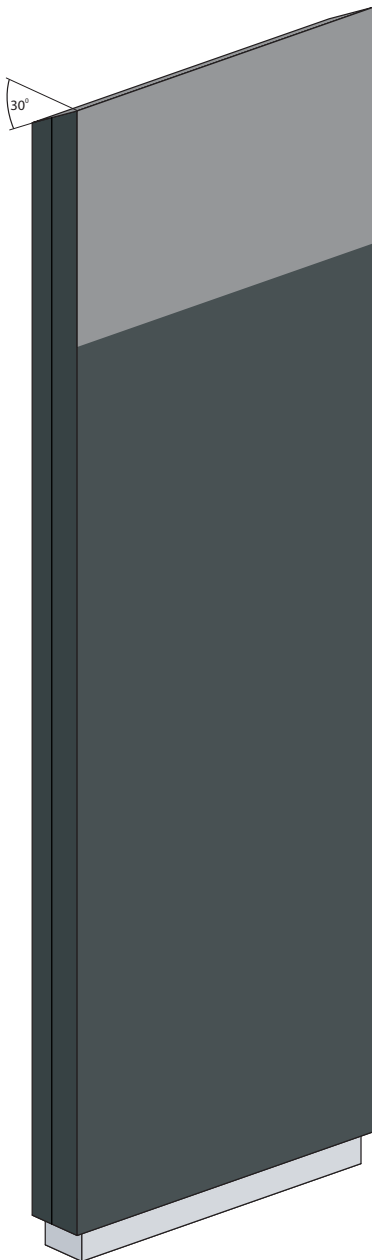

Larger monoliths
exceeding 4250mm
in height

Specification principals for all low level monolithic signs exceeding an overall height of 4250mm to be read in conjunction with the exploded view drawings on the following page.

The front and back panels are to be fabricated out of 3mm aluminium panels. Blanks are to be cut out and folded to shape. The folded corners are to be fillet welded and dressed. See drawing attached for exact specifications and note that the cross beams prevent the front face from denting inwards and stop the unit from twisting. Two, 150mm post sections (wall thickness 3mm) to extend the full height of the sign.

Steel foot plates to be bolted to a steel M20 rag-bolt cage and levelling plates cast into concrete bases (3 parts 19mm chippings, 2 parts coarse sand, 1 part cement) on site into substantial concrete foundations, likely to be in the region of the region of 1.5 cubic metres of concrete. Exact size of foundations for each size of Gateway Sign to be advised in due course.

Accurate manufacture of all monolithic structures to a tolerance of ± 1 mm is essential to ensure that front or rear panel sections of any monolith are interchangeable with any unit of a similar size at a later date.

Plinth should be constructed from brushed stainless steel with secret fixings.

3.5 | Tray sign construction

Type A

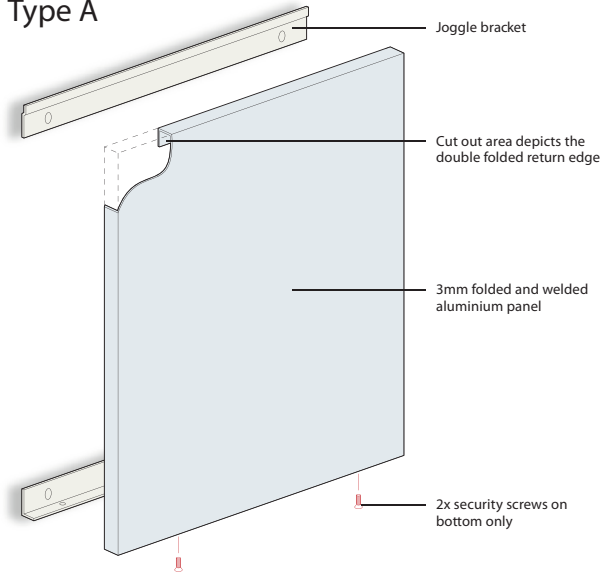

Wall mounted tray signs are to be made from 3mm aluminium, routed to shape with folded returns. The corners are to be fillet welded and finished square. A 15mm thick high impact polystyrene block is to be taped to the inside face to help prevent denting. The top horizontal line of the tray is to have a double fold that hook over a wall mounted angled joggle bracket with the bottom horizontal line held in place by a 90° angled bracket with two flush mounted security machine screws. This ensures that there are no visible fixings to be seen.

450 x 450mm trays to have 20mm returns.
 600 x 600mm trays to have 20mm returns.
 700 x 700mm trays to have 30mm returns.
 900 x 900mm trays to have 30mm returns.

Type A = Wall Fixed
 Type B = Glazing Fixed
 Type C = Fence Fixed

Type B

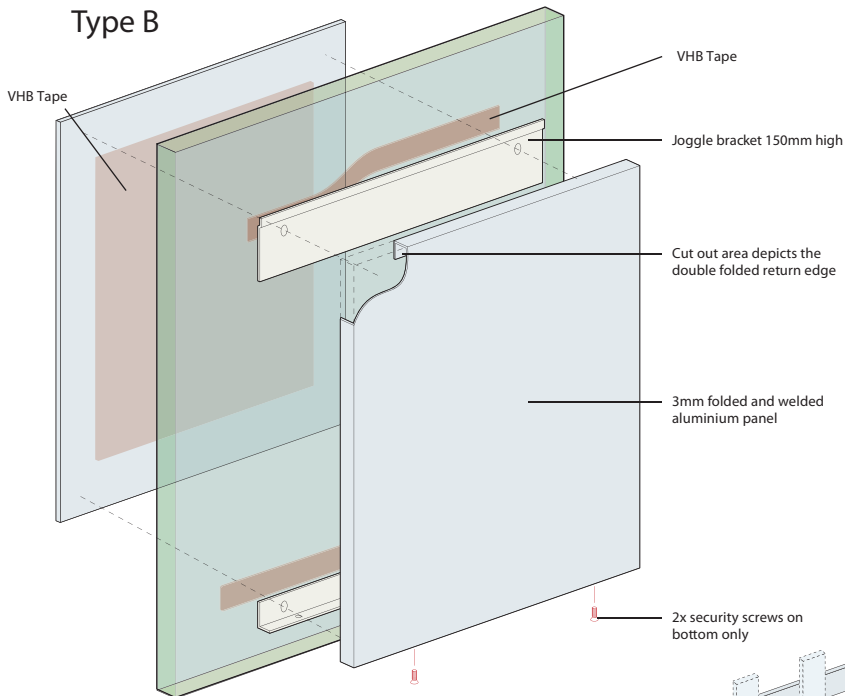

Type C

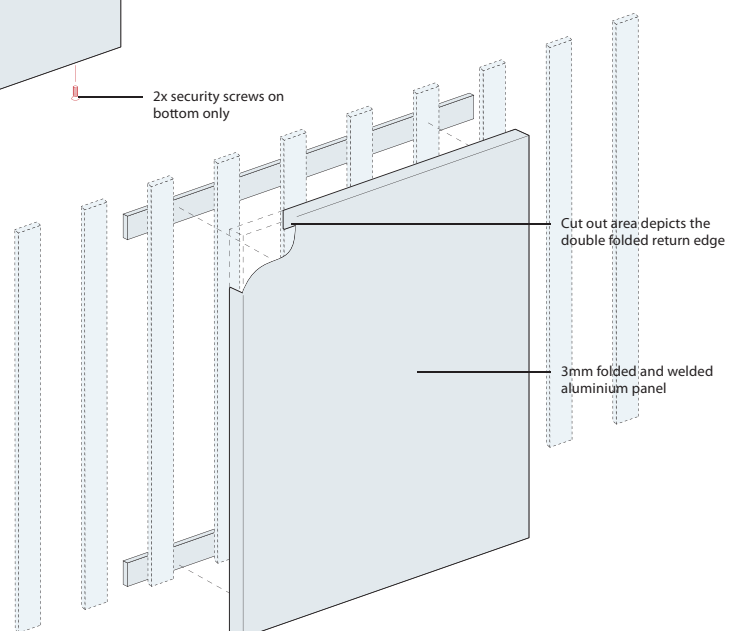

Security Intercom

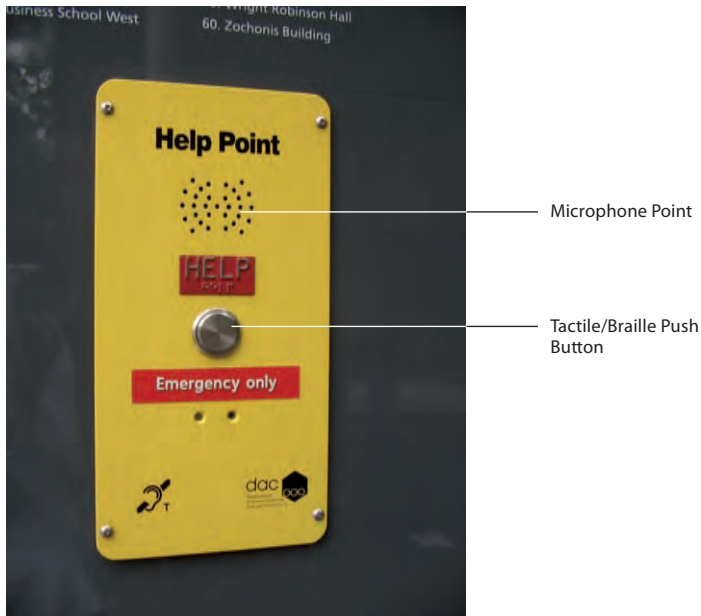

Suppliers: GAI Electronics

Part Number for special back box is: 501-09-0114-00
(please note back boxes are on a 6 week lead time)

Hot spot and selected campus map signs will incorporate security intercoms to be manufactured to the following specification: An audible security intercom device is to be installed behind the surface of these signs.

The intercom device is to be vandal resistant and have an IP rating of IP65 or above. Intercom to incorporate an induction loop facility in order to amplify sound for the hard of hearing.

An interface device to a telephone within a security office will also be needed (hard wiring by others).

Unit to be positioned 1000mm above finished floor level.

3.7 | High Level Tray Sign (A)



Tray (Logo Panel)

The University
of Manchester

For specifications on lettering
- see following page

High level signs comprise of aluminium trays and shallow built up letters. Use the specification on this page in conjunction with the illustrated specification drawing on the following page.

Trays

These are constructed from 3mm aluminium sheet with folded and fillet welded corners finished square. Fixing comprise of large aluminium angle brackets equal to the signage contractor of each tray. Trays to be flush mounted to wall surfaces.

Size of each tray to be determined by the space available on each individual building based on a survey undertaken by the tender applicants and using the numbered photographs in section B as a guide.

The return depth of the tray is relative to its size. The following calculation can be used on the tray size to determine the return depth:

Return depth = 5% of tray width (i.e. 4m wide tray = 200mm return)

3.7.1 | High Level Letters (B)



For tray specifications
- see previous page

The University
of Manchester

Individual built up letters

Built up de-scaled steel letters with bespoke stainless steel locators (male / female) mounted onto bridge brackets which span the rear of each letter (see drawing).

The distance from the wall to the rear edge of the letter to be determined by the size of each letter which in turn is determined by the space available on each individual building.

Examples of the ratio of size of letter to size of return to the set off space between wall and letter to be as follows: The depth of the letters is relative to their cap height. The following calculation can be used on the letters to determine the depth (the result from this calculation is also equal to the distance that each letter should stand off the wall):

Letter depth = 5% of Cap Height but to a minimum of 10mm (i.e. 500mm High Letters = 25mm return & 25mm gap between back of letter and wall)

3.7.2 | High Level - Bird Deterrents



4 rows of stainless steel pins protruding at 4 different angles

All high level signs (both tray and individual letters) to have anti-roosting bird spikes installed along upward facing horizontal surfaces to prevent pigeons & seagulls from perching. Only 'Pigeonproof' pigeon spikes approved and recommended by the RSPB (Royal Society for the Protection of Birds) and PICAS (The Pigeon Control Advisory Service) are to be used.

Only stainless steel dense protruding pin patterns to be used due to their high exterior life and discrete nature.

Installation

Spikes to be glued to upward facing horizontal surfaces that pigeons might sit to manufacturers specification.

Surfaces greater than 200mm will need 2 or more rows for optimum protection.

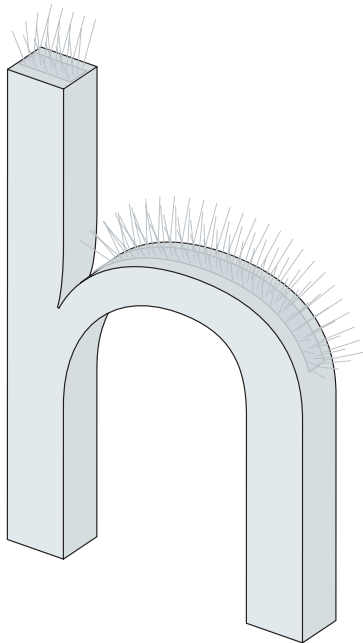

Bird spikes glued to upper surfaces of letters

3.9 | Decorative Base Units

Type A - Non-illuminated monoliths

To protect monoliths located in grassed areas from damage caused by lawnmowers etc, a decorative base unit must be constructed as part of the sign installation. The base is constructed from flush granite sets onto a 100mm deep concrete base.

This style of base unit should be used on monoliths that do not require close-up reading positioned within grassed areas.

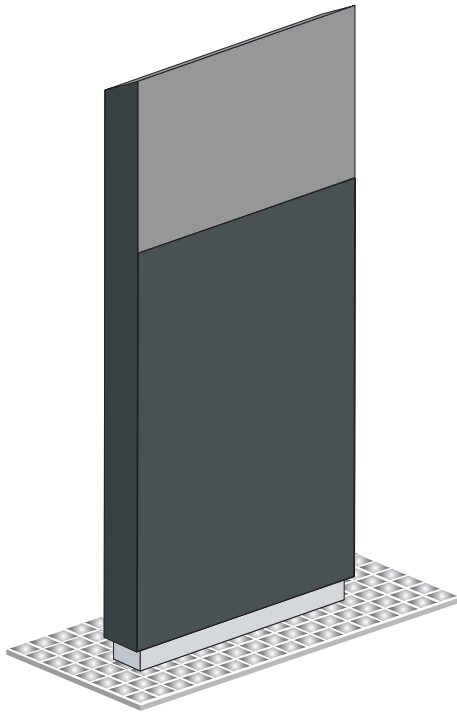

Overhead View

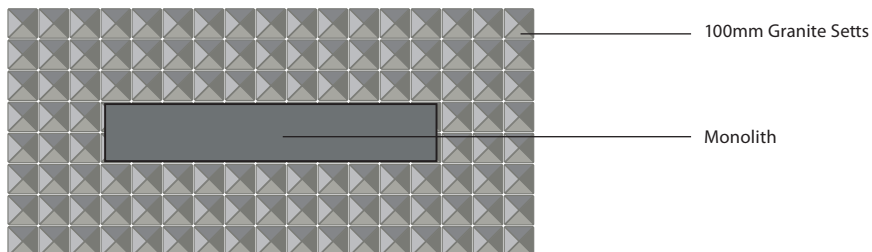

3.9.1 | Decorative base

Type B - Illuminated Monoliths

This base unit is installed when an illuminated monolith is located within a grassed area and content requires close-upreading (i.e. campus maps and hot spotsigns).

The base has the inclusion of an 'information floor surface' to assist people with disabilities to identify the location of the sign. The information surface does not have a raised profile but is detectable because it feels slightly softer underfoot than conventional paving materials. The surface should have a matt finish and be slip resistant.

The information surface should be non-bituminous and based on a neoprene rubber or similar elastomeric compound. It should be a contrasting dark grey/black colour to the surrounding footway to assist partially sighted people.

Lighting

The base has two flush mounted walk over uplighters which have toughened glass lens and stainless steel surrounds.

The uplighters should have an angled reflector to flood the face of the sign with illumination.

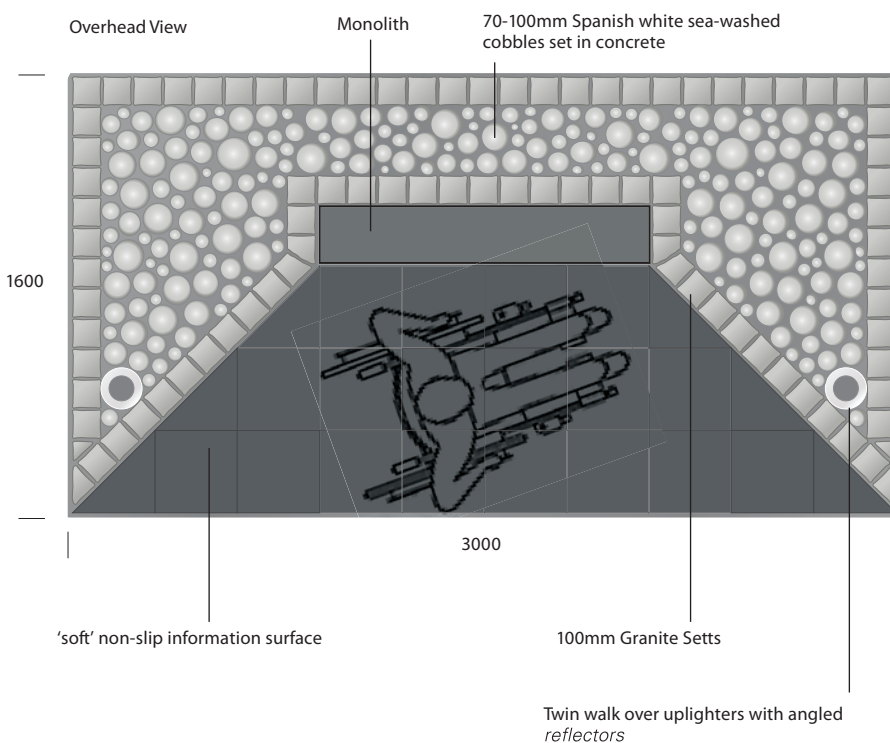
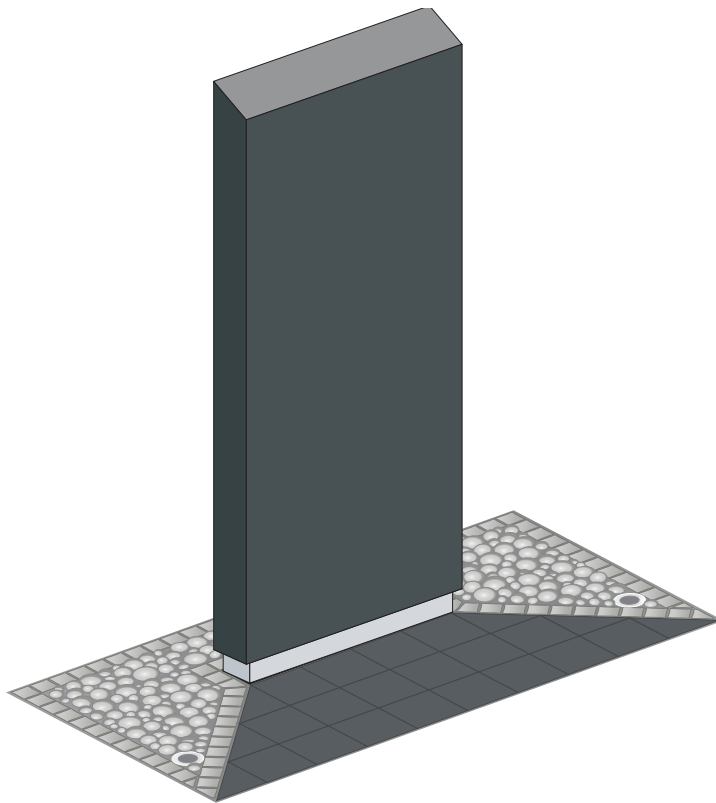

'Nimbus' uplighter - for monoliths beneath a height of 2.5m.

'Pharo' uplighter - for monoliths above a height of 2.5m.

Light units are available from specialist lighting company Louis Poulsen (01372 848800).

Contractor to include for the provision of dropped kerbs in front of each unit to allow access for wheelchair users where appropriate.

For variations please consult the Design Services Group

Luminaire for high level signs

Muralux is a low wattage floodlighting luminaire, combining architectural appeal with lighting flexibility. A selection of five popular light distributions allows total control over the lighting design, whether it is overall wallwashing, highlighting specific points with a spot distribution or throwing light forwards from the luminaire. Muralux has been designed to be slim in appearance to blend into its environment and can be used with a range of different lamp types to produce a myriad of light solutions.

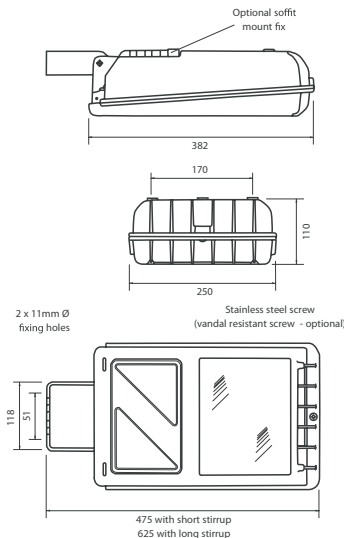

Specification

The luminaire shall consist of a two piece die-cast aluminium housing with a glanded entry for 6-15mm cable and doorframe. The control gear shall be secured to the doorframe and be suitable for a wide choice of high intensity discharge lamps. The front and rear castings shall hinge at the bottom by two secured stainless steel pins. The two castings shall be sealed by an extruded gasket and secured by four stainless steel captive screws ensuring an IP rating of 65. The optical arrangement shall consist of a choice of fluted hydro-formed aluminium reflectors and a fully tempered clear front glass sealed to the doorframe. The luminaire shall be designed to EN60598-2-5 and be mounted by means of a mounting stirrup fabricated from hot rolled steel, providing 360°swivel and complete with horizontal aiming marks on a protractor aiming guide. A range of bracketry and columns are available with additional options and accessories.

Lamp Types(Included)

- 70W - 150W
metal halide (various)

IP Rating

- IP65

Approvals

- EN60598-2-5
-

3.10.1 | Electrical Specification

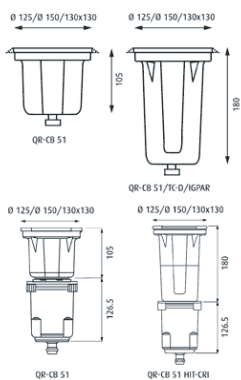

Nimbus Basic for UM17 and selected UM18

Nimbus provides distinct accent lighting and sets scenes, creating drama and highlighting architectural features.

Finish

Stainless steel. Brass, polished.

Material

Sleeve: stainless steel. Glass: Toughened clear glass or toughened frosted glass. Top plate: brass or marine grade 316 stainless steel. Housing: Teflon coated, aluminium coloured, die cast aluminium. Transformer housing: Grey, injection moulded polyetherimide.

Mounting

Sleeve: Recommended mounting in optional installation sleeve. Installation sleeve (Ø129x137/225/300/350mm) to be ordered separately. Ø 125mm is mounted in level with the ground. Ø 150mm is mounted on the ground. Terminal block: Electric shock Protection I: 3x2,5mm², Electric shock Protection III: 2x2,5mm². Cable entries: One-part body: 1xM20 IP68 gland for Ø 6-12mm cable. Two-part body: 2xM20 IP68 gland for Ø 6-12mm cable. Inground: Suitable for burial in earth/pea-shingle or cast into concrete.

Weight

Max. 3.5kg.

Class

Ingress protection IP67. Electric shock protection I w. ground, III low voltage.

Specification

Product code
NIMBAS-A

Ø 150 STRAIGHT

Light source
1x50W QPAR 20 E27

Voltage/Frequency
NOT APPLICABLE
240V/50HZ

STAINLESS STEEL

Reflector
10°

3.12 | Electronic Messaging Board Fixing Specification

Conference Signs UM27

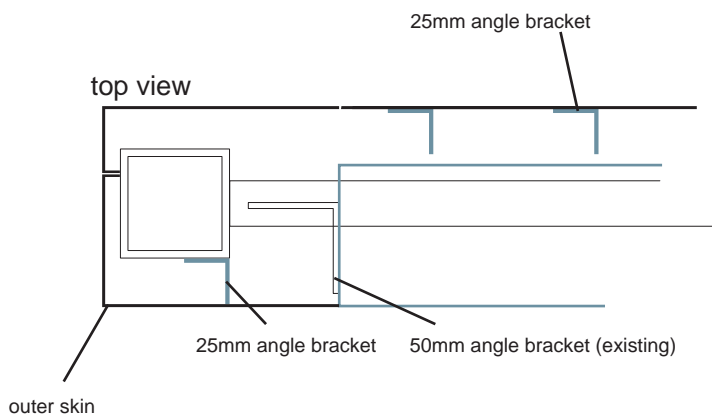
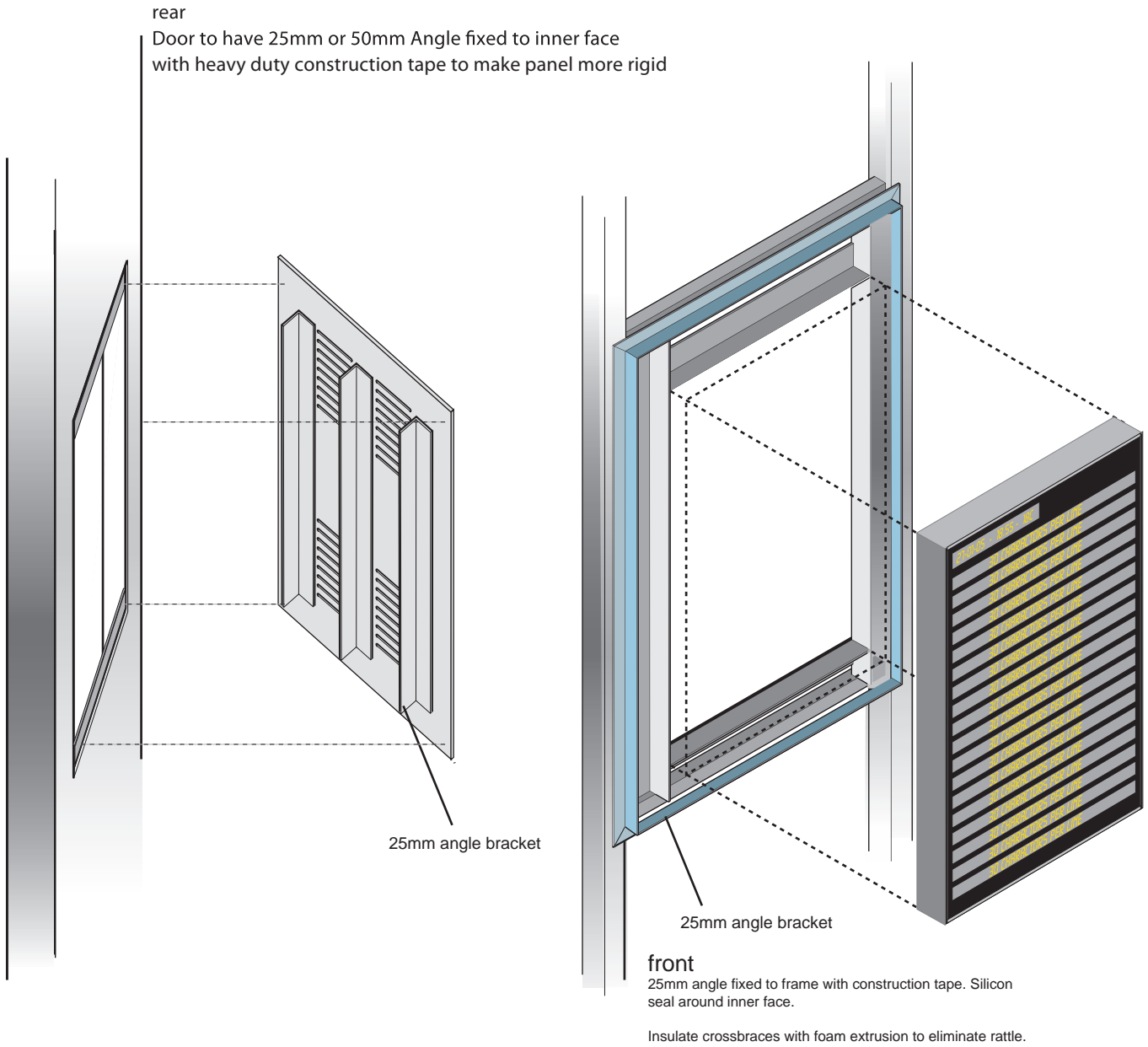

3.12 | Electronic Messaging Board

Conference Signs UM27 Messaging Unit

These products should not be specified or procured without prior written consent from the Directorate of Estates

Messaging units should have 17 lines of text and 1 line at the top to show the time/temperature 30 characters
The bottom line of text should be scrolling

Product Reference
SEB/1830/UBY/TTD/SCROLL/NETWORK CARD
Further information please contact
www.scanlite.co.uk

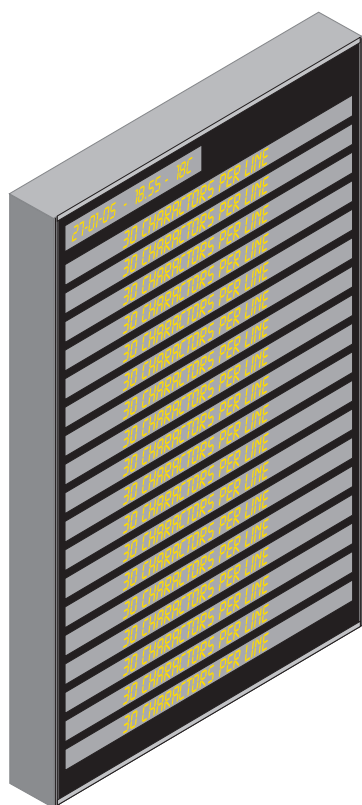

1140mm

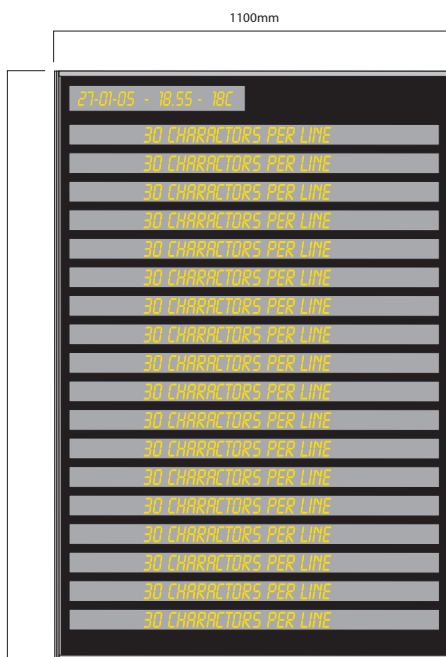

3.13.2 | Electrical Specification

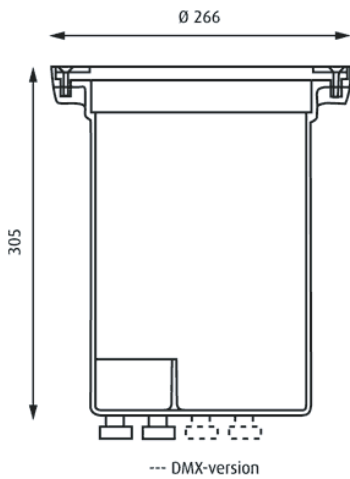

Pharo Clear LED for UM01

Pharo Clear LED provides accent illumination and colour for large features.

Finish
Stainless steel.

Material
Sleeve: Stainless steel. Glass: Toughened clear glass. Top plate: marine grade 316 stainless steel. Housing: Teflon coated, aluminium coloured, die cast aluminium.

Mounting
Sleeve: Recommended mounting in optional installation sleeve. Installation sleeve ($\varnothing 272 \times 350$ mm) to be ordered separately. Terminal block: $2 \times 3 \times 2.5$ mm². Cable entries: Standard: $2 \times M25$ IP68 gland for $\varnothing 13$ - 18 mm cable. DMX: $2 \times M25$ IP68 glands for $\varnothing 13$ - 18 mm cable. $2 \times M20$ IP68 glands for $\varnothing 6$ - 12 mm cable. Looping: Approved, maks. 3×2.5 mm². In ground: Suitable for mounting in wood, burial in earth/pea shingle, or cast into concrete.

Weight
Max. 10kg.

Class
Ingress protection IP67. Electric shock protection I w. ground.

Specification

Product code
PHARCLR-A

Light source
180 LED White Nom load 30W

Finish
STAINLESS STEEL

3.13.4 | Switchlite Exterior Photocell

Overview

For use with Illuminated signs
Please see Directorate of Estates for advice on usage.

Standard Photocell
Fits directly into road lighting lanterns having a NEMA socket. (Designated by the letter 'P' in the old catalogue number).

Photocell Kit
Consisting of a photocell, socket and mounting bracket for use with luminaires that do not have an integral photocell socket.

Part Night Photocell Kit
Switches on at dusk and then off at midnight; if it is still dark it will switch on again at about 6.00am and then off at dawn. A dedicated integrated circuit calculates the time automatically. This unit is only available in kit form with a socket and mounting bracket.

Materials/Finish
Enclosure: polycarbonate.

Installation/Mounting
Electronic thermal relay for loadswitching.
Voltage range: 198-264V A.C.
Switch-on level: 70 or 75 lux
Switch-off differential:
Max. 1.5 x switch-on level.
Load switching capacity:
5A (for discharge lamps use starting current).
Max. power factor correction: 60mF.
Switching delay: 60 secs
Power consumption: 3W during daylight only.

Specification
To specify state:
Photocell to fit NEMA socket (or photocell kit) with 70-75 lux switch-on level and 1.5 maximum differential and 5A switching capacity.
As Thorn Switchlite Exterior Photocell.

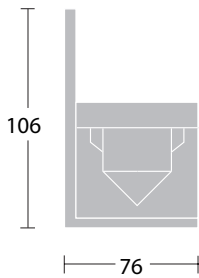

Base holder and bracket

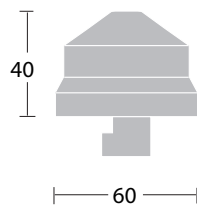

QP Photocell

Internal Signage

- 4.0 Introduction
- 4.1 Entrance Directory UM30
- 4.2 Freestanding Entrance Directory UM31
- 4.3 Floor Level Information and Directional UM32
- 4.4 Supplementary Directional UM33
- 4.5 Room Numbers and Permanent Sign Information
UM34 & b
- 4.6 Room Numbers only UM35
- 4.7 Room Numbers and Paper Inserts UM36
 - 4.7.1 Paper Insert Template
- 4.8 Acrylic Wallets for Temporary Information UM36b & c
- 4.9 Department Title UM37
- 4.10 Floor Level Information UM38
- 4.11 Toilet Signs UM39
- 4.12 Projecting Signs UM40
- 4.13 Wall Mounted Commemorative Plaque UM45
- 4.14 Internal Grade Postercase UM50
- 4.15 Symbols

4 | Internal Signs

Wayfinding general guidance

Information on signs should be clear and concise, and general so not to confuse people, for example

A directory should refer to Finance Department as the overall department not a list of

- VAT Office
- Cash Office
- Wages

If a person needs did not fit into any of the particular categories they would not know where to go.

Directories and Directional signs information should be limited to information that isn't likely to change in the short to medium term.

Peoples Names should be limited to the paper inserts part of the room identification signs.

Directional Information should be positioned at every MAJOR junction/decision making point.

For buildings with high new visitor numbers consideration should be given to signing the wayout, exit or back to reception.

Text should always be leading upper and lower case except for acronyms

For example:
Student Services Office
A.C.A.S

This enables people with some visual impairment to see each individual word more clearly.

Some buildings and departments may be challenging in terms of wayfinding due to unusual architecture or departments being on different levels/areas. In these circumstances please consult an approved signage contractor for advice.

Information to be put on signs should be used consistently throughout the university, be clear and concise. Generally one destination should be used per panel, where the amount of text is too long for one standard size, panel size to be increased from 45mm to 75mm and text split at an appropriate point and a second line of text introduced.

This process to be adapted when there is subordinate text under a heading but 2nd line of text to be indented.

Consideration should be given to the space either side of the sign as panels need to be removed by sliding to the side.

4 | Internal Signs

Specification and graphic content of the internal signs

Internal signs should be made from the following extruded aluminium systems

HB Modular Sign System
The Classic
MSS

The system is a simple assembly of strong, lightweight, extruded interchangeable aluminium panels.

The system panels are securely held together by integral dovetails and when fitted together have no visible frame or fixings.

The system is very flexible panels can be changed simply and additional panels can be easily added to existing signs.

Signs should always have a TP and BP at the top and bottom of and projecting signs. These finishing profiles make the signage system more secure and vandal resistant.

The system comes in components ranging from 10mm to 150mm high, the number of components to be used has been limited to a small range of component sizes to achieve consistency throughout the campus

Finish specification

All graphics should be screen printed rather than self adhesive vinyl to reduce the affects of vandalism.

Each panel should be anodised, acrylic painted and then stoved for durability.

All bottom profiles will be in the corporate light grey and have a unique code printed in the corner for maintenance.

Code comprises: 5 Digit Building reference number / 3 Digit Sign reference number commencing at 001 IE 084AA/001

Building reference number is available from the Design Services Groups - Development Team - Space Planner.

The header panel should RAL 7046 light grey and the other panels RAL7015 dark grey or Pantone 2602C purple as indicated on individual sign types.

All signs should be screw fixed unless in areas that are safe from vandalism or are not suitable for screw fixing.

The surface to be fixed to should be cleaned and any loose debris removed. Signs should have Novabond or equal and approved very high bond foam tape applied to rear horizontally to the full width of the sign.

These should then be physically or mechanically held until the adhesive has suitably set to hold/support the fixings and the sign.

Alternatively signs should be screw fixed when adhesive fixing is not suitable.

Glass fixing

Where the only suitable position for the sign is to fix to glass, a dark grey vinyl panel the same size as the sign should be fixed to the other side to hide the VHB tape fixing.

4.2 | Internal Signage

Freestanding Directory UM31

Where there are no suitable positions to wall mount a sign due to building constraints such as glass, coving or when there is no suitable space at the side of the sign position to remove the panels, the freestanding option should be used.

Graphics

Refer to Entrance Directory sign information.

Colours

25mm MDF panel to be sprayed dark grey.
Base to be sprayed silver

Weights should be fixed in the bottom of the base. Single sided preferred

Components

Refer to Entrance Directory

Text in line with logo

650

30mm CAP ht centred vertically

1950mm

7mm CAP

001AA/MD001

15

Toilet information is 3 blank panels below all other information

Coupland III Building	
Central Teaching Lecture Rooms nos. LH.9, LG.10, LG.12, LG.13, LG.14	B
Central Teaching Lecture Theatre (Bengar Theatre)	2
Central Teaching Lecture Theatre A	G
Central Teaching Lecture Theatre B	1
Central Teaching Lecture Theatre C (use alternative building entrance)	2
Central Teaching Seminar Room no. LG.6	B
CPPE (use alternative building entrance)	2
Drug Usage and Pharmacy Practice Group (DUPPG)	G
Pharmacy Conference Room	1
Pharmacy Practice Research Resource Centre	G
School of Nursing, Midwifery and Social Work; Reception	1
School of Pharmacy and Pharmaceutical Sciences; Reception	G
School of Dentistry	G & 3
School of Pharmacy and Pharmaceutical Sciences	B, 1,2,3,4
Student Computer Cluster	1
Teaching Rooms 1.28, 1.29, 1.31 & Cope	1
University Press	G, 1 & 2
Pharmacy Conference Room	B, 1 & 2
Toilets	G, 1 & 2
Toilets	B, 1 & 2
Toilets ♿	1



Internal Signage

Freestanding Directory Double Bank

Text in line with logo

650

The University of Manchester

MANCHESTER 1824

Coupland III Building

30mm CAP

Central Teaching Lecture Rooms nos. LH.9, LG.10, LG.12, LG.13, LG.14	B	Central Teaching Lecture Rooms nos. LH.9, LG.10, LG.12, LG.13, LG.14	B
Central Teaching Lecture Theatre (Bengar Theatre)	2	Central Teaching Lecture Theatre (Bengar Theatre)	2
Central Teaching Lecture Theatre A	G	Central Teaching Lecture Theatre A	G
Central Teaching Lecture Theatre B	1	Central Teaching Lecture Theatre B	1
Central Teaching Lecture Theatre C (use alternative building entrance)	2	Central Teaching Lecture Theatre C (use alternative building entrance)	2
Central Teaching Seminar Room no. LG.6	B	Central Teaching Seminar Room no. LG.6	B
CPPE (use alternative building entrance)	2	CPPE (use alternative building entrance)	2
Drug Usage and Pharmacy Practice Group (DUPPG)	G	Drug Usage and Pharmacy Practice Group (DUPPG)	G
Pharmacy Conference Room	1	Pharmacy Conference Room	1
Pharmacy Practice Research Resource Centre	G	Pharmacy Practice Research Resource Centre	G
School of Nursing, Midwifery and Social Work; Reception	1	School of Nursing, Midwifery and Social Work; Reception	1
School of Pharmacy and Pharmaceutical Sciences; Reception	G	School of Pharmacy and Pharmaceutical Sciences; Reception	G
School of Dentistry	G & 3	School of Dentistry	G & 3
School of Pharmacy and Pharmaceutical Sciences	B, 1,2,3,4	School of Pharmacy and Pharmaceutical Sciences	B, 1,2,3,4
Student Computer Cluster	1	Student Computer Cluster	1
Teaching Rooms 1.28, 1.29, 1.31 & Cope	1	Teaching Rooms 1.28, 1.29, 1.31 & Cope	1
University Press	G, 1 & 2	University Press	G, 1 & 2
Pharmacy Conference Room	B, 1 & 2	Pharmacy Conference Room	B, 1 & 2
Toilets	G, 1 & 2	Toilets	G, 1 & 2
Toilets	B, 1 & 2	Toilets	B, 1 & 2
Toilets ♿	1	Toilets ♿	1

1950mm

DOTAA / MD001

7mm CA

15

Toilet information is 3 blank panels below all other information

4.3 | Internal Signage

Maximum 14 panels + header

545

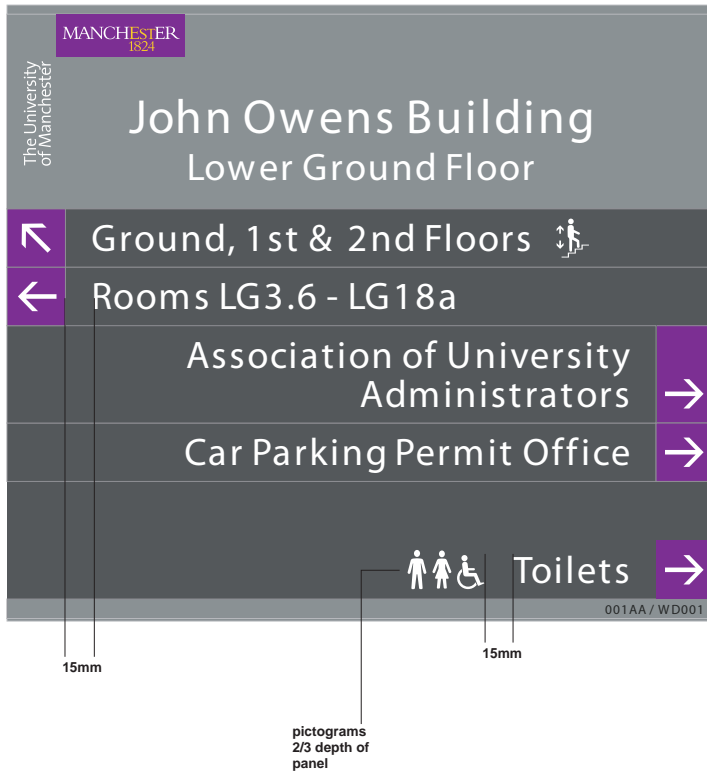

Floor Level Information and Directional UM32

This sign to be used to establish which level people are on when arriving from a lift or stairwell or a building entry point and a wayfinding decision needs to be made immediately.

Preferred location is opposite stairwell or lift.

Maximum of the top of the sign to the floor is 1950mm.

Minimum of the bottom of the sign from the floor is 800mm.

The ideal range of heights for positioning should be between 1400mm x 1700mm above finished floor level.

Fixing

Signs to be screw fixed to walls.

Graphics

Header Panel 30mm Building name

20mm Floor level and Directionals

The Sans Plain

Components

Multiple 45mm high panels should be used.

Purple is 45mm x 45mm

75mm panels to be used for 2 lines of text.

Minimum 15mm border at either side of the text.

sizes for UM-38	Width	Height	Depth
Width/Height Will be determined by the amount of information required	Optimum Width 600mm	150/45mm	6mm

4.4 | Internal Signage

Maximum 14 panels + header

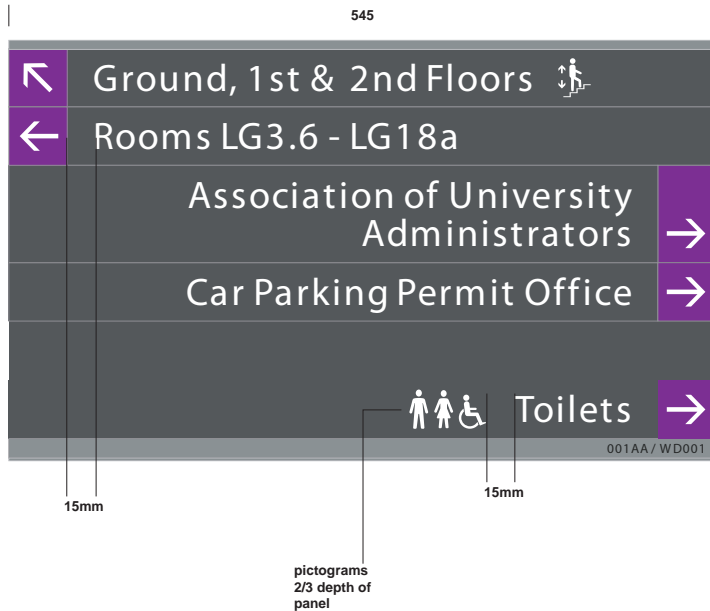

Supplementary Directional Signs UM33

To be used when a wayfinding decision needs to be made within a building.

Preferred position is on a wall opposite the decision making point.
Information should be limited to directions to room numbers and key areas.

Maximum at top 1800mm

Signs can be fixed with very high bond tape in areas that are safe from vandalism or surfaces are not suitable for screw fixing.

Graphics
Type Height 20mm Capital.
The Sans Plain

Components
Multiple 45mm high panels should be used.
For two lines of text 75mm high panels should be used.

NB. In all cases - Hierarchy of arrows need to be adopted/maintained.

Where length of text is larger than available space the text is to be split at suitable location and two lines used on a 75mm high profile.

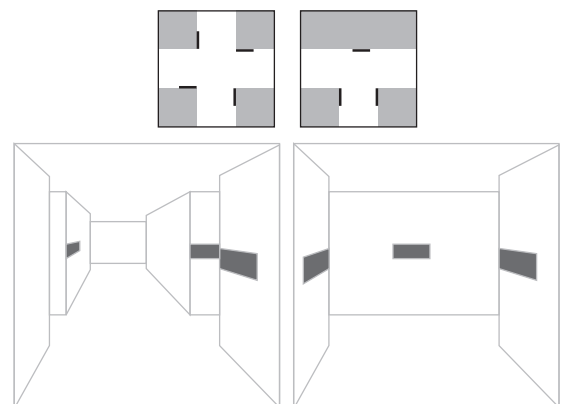

4.5 | Internal Signage

Room Numbers And Permanent Sign Information UM34 & 34b

Standard slider assembly 30mm high option with free or engaged slider

To be used to identify key rooms and areas where the name or title of the room or area will remain for a significant period of time.

Signs should be positioned on the wall at the leading edge side of the door where possible. If this is impossible due to size constraints an alternative position as close to the door at the same level should be used. Where this is also impossible signs can be positioned on the doors providing they have closers.

Any objects that are obstructing the signage position should be found alternative locations.

The sign should be positioned with 1400mm to the underside of the room number panel.

Signs to be screw fixed to walls
Signs can be fixed with very high bond tape in areas that are safe from vandalism or surfaces are not suitable for screw fixing.

Graphics
Type Height 20mm Capital.
The Sans Plain

Components
Multiple 40/30/15mm high panels should be use

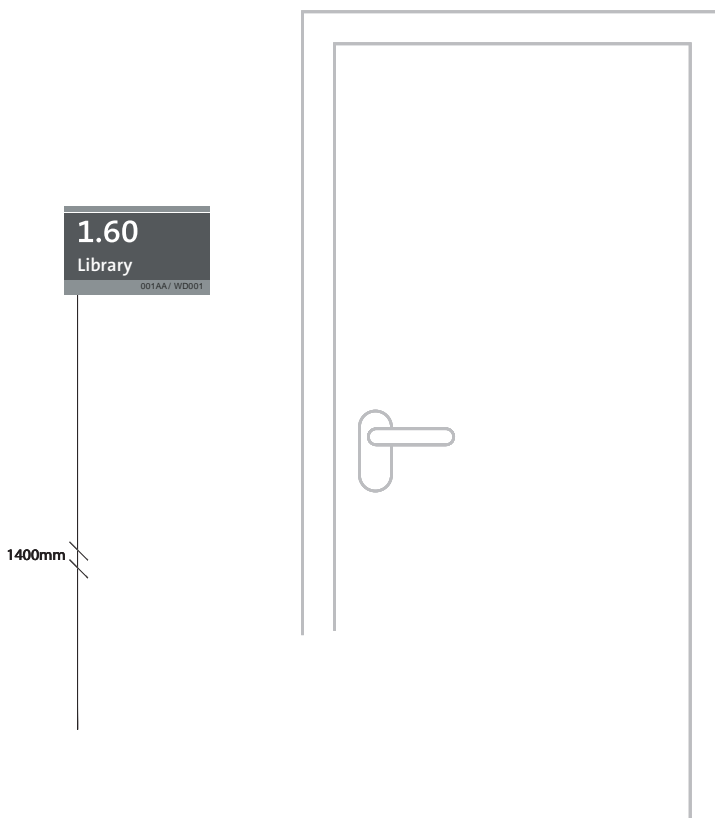
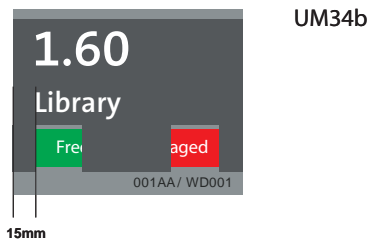
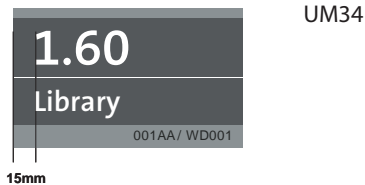

4.6 | Internal Signage

Room Numbers UM35



To be used to identify minor rooms that do not require supplementary information. Signs should be positioned on the wall at the leading edge side of the door where possible. If this is impossible due to size constraints an alternative position as close to the door at the same level should be used. Where this is also impossible signs can be positioned on the doors providing they have closers.

Any objects that are obstructing the signage position should be found alternative locations. The sign should be positioned with 1400mm to the underside.

Signs to be screw fixed to walls
Signs can be fixed with very high bond tape in areas that are safe from vandalism or surfaces are not suitable for screw fixing

Graphics
Type Height 25mm Capital
The Sans Plain

Components
A P40 panel should be used

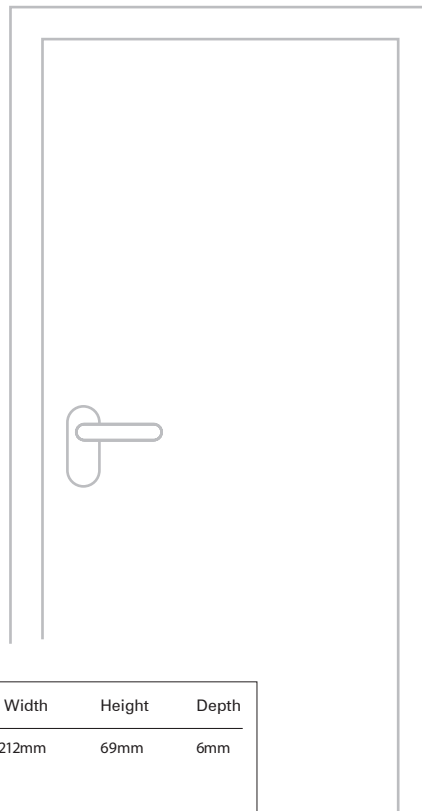

Sizes for UM32	Width	Height	Depth
	212mm	69mm	6mm

4.7 | Internal Signage

Width 212mm

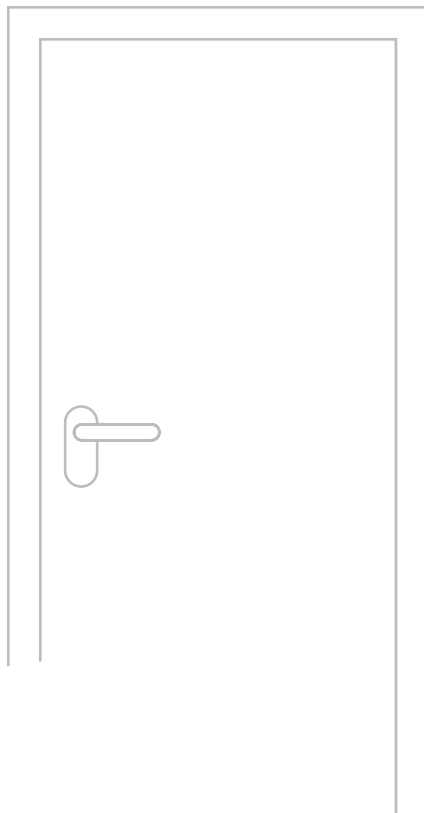
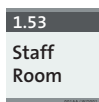
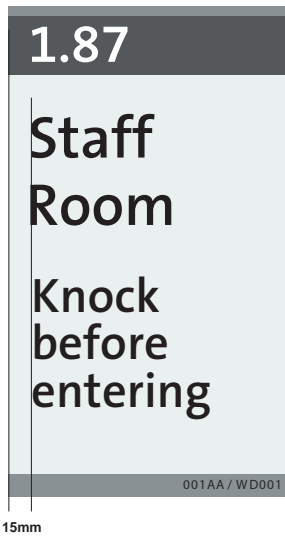
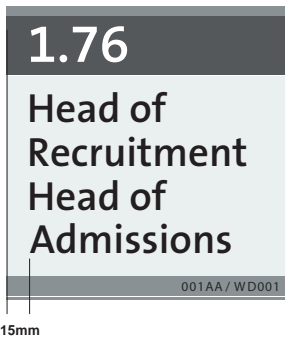
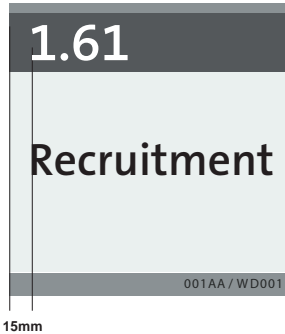
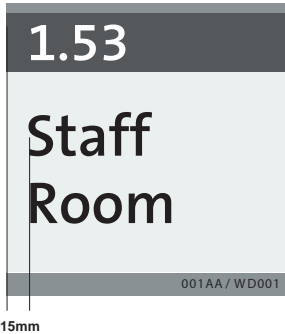

Room Numbers And Paper Inserts UM36

To be used to identify key rooms and areas where the name or title of the room or area is likely to change.

Signs should be positioned on the wall at the leading edge side of the door where possible. If this is impossible due to size constraints an alternative position as close to the door at the same level should be used. Where this is also impossible signs can be positioned on the doors providing they have closers.

Any objects that are obstructing the signage position should be found alternative locations

The sign should be positioned with 1400mm to the underside of the header panel

Signs to be screw fixed to walls.
Signs can be fixed with very high bond tape in areas that are safe from vandalism or surfaces are not suitable for screw fixing.

Graphics
Type Height 20mm Capital.
The Sans Plain

Paper insert information minimum 7.5mm
All text should be the corporate font which is available from public relations

Size
Sign should be made from A5 Landscape acrylic wallet and header panel assembly.

4.8 | Internal Signage

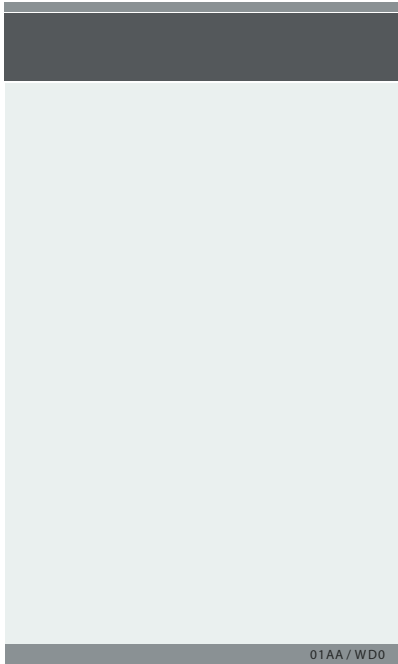

Acrylic Wallets for temporary information UM36b & c

To be used to house paper inserts for Health & Safety information.

To be fixed with VHB tape to smooth walls or door if necessary.

The sign should be positioned with 1100mm to the underside.

Signs should be positioned on the wall at the leading edge side of the door where possible. If this is impossible due to size constraints an alternative position as close to the door at the same level should be used. Where this is also impossible signs can be positioned on the doors providing they have closers.

Any objects that are obstructing the signage position should be found alternative locations.

Graphics
paper insert only

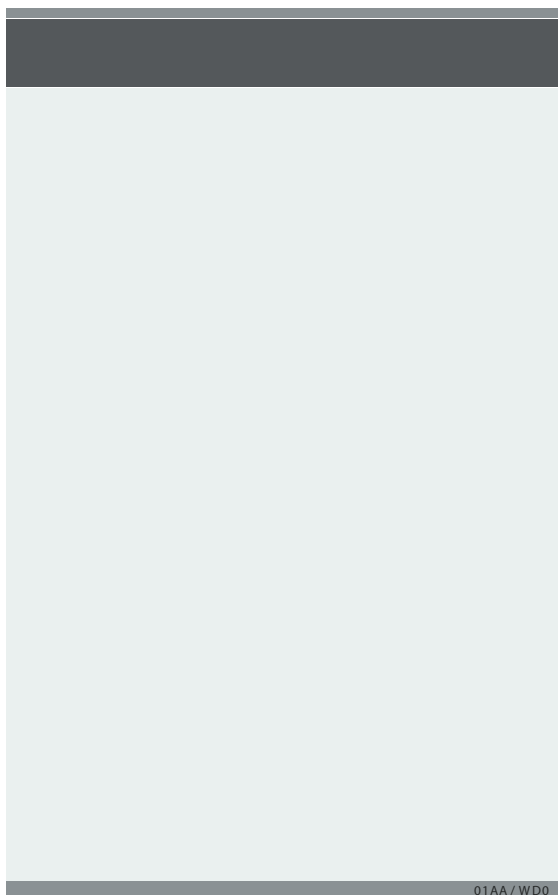

Paper insert information As per Health & Safety guidelines.

Size
A4/A3 Portrait plus 40mm header panel.

Fixing
Signs to be screw fixed to walls.
Signs can be fixed with very high bond tape in areas that are safe from vandalism or surfaces that are not suitable for screw fixing.

If required the room numbers can be printed on the top panel.

4.9 | Internal Signage

Department Title UM37

To be used to identify an area within a building that is specific to that department only

Preferred position on the wall at the entrance to the area.

The sign should be positioned with 1400mm to the underside
Alternative location is above doors to entrance to area

Signs to be screw fixed to walls Signs can be fixed with very high bond tape in areas that are safe from vandalism or surfaces are not suitable for screw fixing

Graphics

Type Height 30mm Department title (1line)
25mm 2 lines
25mm School or division
The Sans Plain

Components

Multiple P120mm high panels should be used.

Sizes to suit building architecture refer to Design Services Group for guidance.

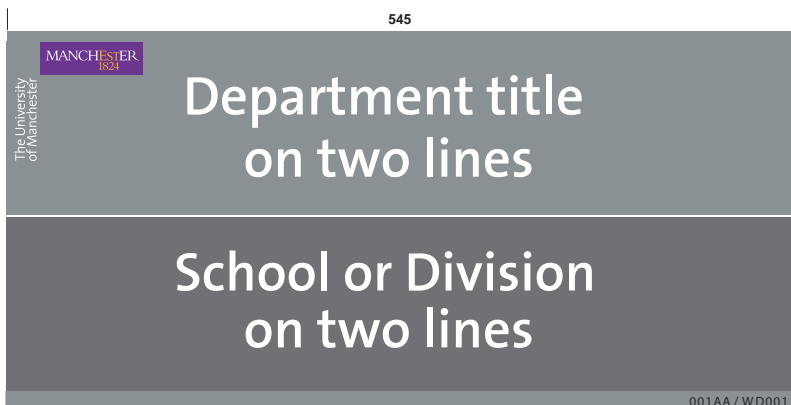
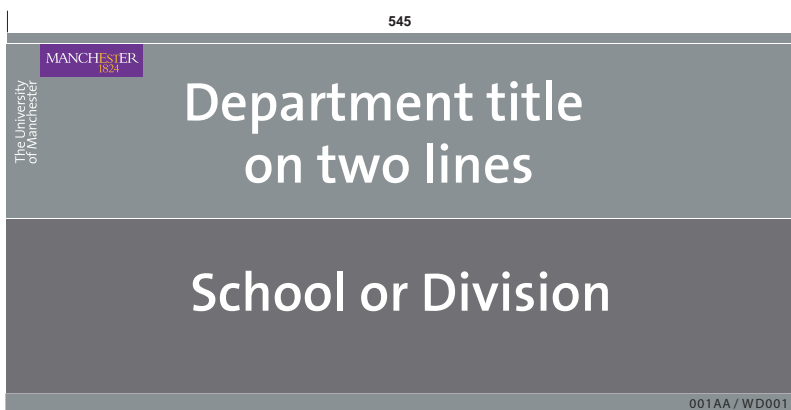

sizes for UM-37	Width	Height	Depth
Width/Height Will be determined by the amount of information required	Optimim Width 545mm	120mm	6mm

4.10 | Internal Signage

Floor Level Information UM38

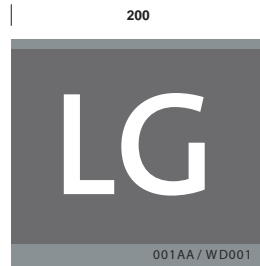

To be used to establish which level people are on when arriving from a lift or stairwell

Preferred position on the wall opposite the lift or stairwell
The sign should be positioned with 1400mm to the underside

Signs to be screw fixed to walls
Signs can be fixed with very high bond tape in areas that are safe from vandalism or surfaces are not suitable for screw fixing

Graphics
Type Height 75mm Capital
The Sans Plain

Components
150mm high panels should be used

Sizes for UM37	Width	Height	Depth
	212mm	150mm	6mm

4.11 | Internal Signage

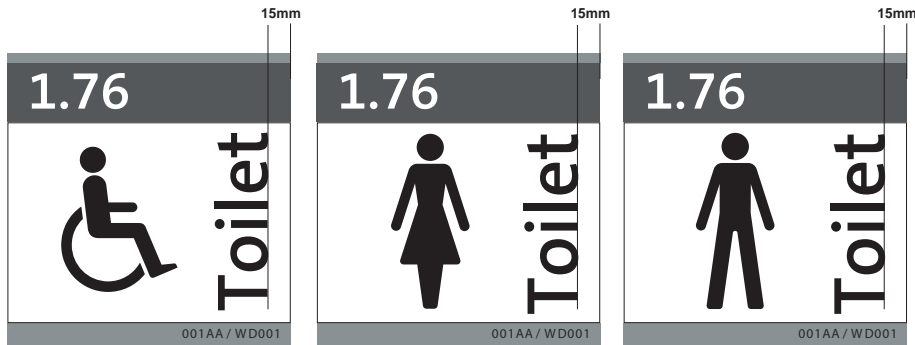

Toilet Signs UM39

Preferred position is centrally fixed directly to doors

The sign should be positioned with 1400mm to the underside.

Fixing

Signs to be screw fixed to doors

Signs can be fixed with very high bond tape in areas that are safe from vandalism or surfaces not suitable for screw fixing

Graphics

Symbols and wording to be black, numerals to be white

Text Height 20/40mm

The Sans Plain

Symbols 140mm high

Components

1 No 40mm, 1 No 15mm and 1 No 212mm high panels should be used

Sizes for UM39	Width	Height	Depth
	212mm	30mm 45mm 150mm	6mm

4.12 | Internal Signage

Projecting Sign UM40

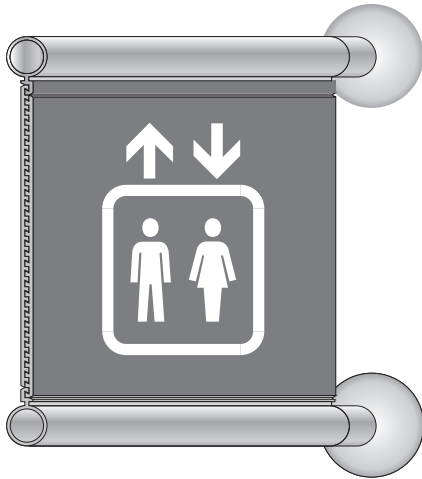

To be used to identify locations of recessed destinations such as toilets or lifts in long corridors or narrow walkways. Preferred position to be fixed directly and centrally above the recess with at least 2300mm from floor to the underside of the sign.

Signs to be screw fixed to walls

Graphics
Double Sided
The Sans SemiBold

Symbols 140mm high

Components
2 No 150 high panels should be used

Sizes for UM40	Width	Height	Depth
	212mm	150mm	6mm

4.14 | Internal Signage

Internal Grade Postercase UM50



To be used to display temporary information larger than A3 size

Construction

Extruded aluminium frame

Fire Resistant internal components

Visual panel to be made from toughened glass

Colour

Dark Corporate Grey Frame & Pinboard

Position

To be fitted with no less than 800mm to the underside

Size

To suit poster requirements



4.15 | Symbols

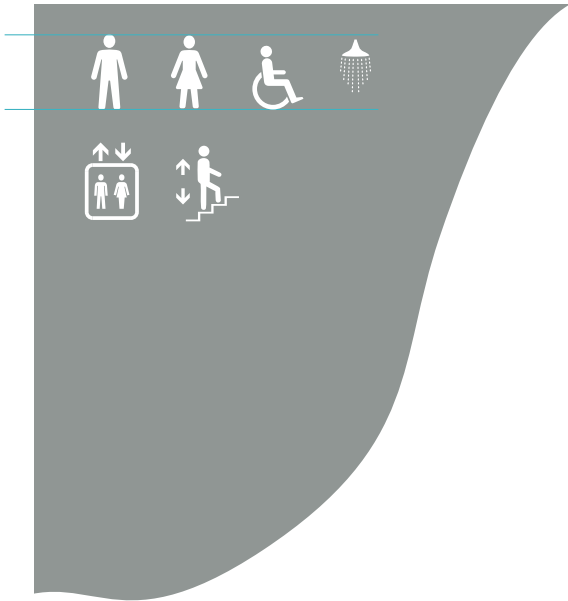

Icons - usually 2/3 panel depth and spaced 20mm from text toilet icons are based on gentlemen height so as to maintain proportion for disabled icon - if disabled icon is used on it's own then this is to be 2/3 panel depth



arrow pictogram depth increased for left registered text on a double panel arrow pictogram depth increased for right registered text on a double panel -arrow position to bottom

Internally Illuminated Building Name Signs UM06b & UM06c

These signs are to be used in areas where the information needs to be read in darkness and there are no other suitable means of illumination.

Illuminated Building Identification Signs

Wall mounted fabricated lightbox comprising 1no. 1110mm high 870mm wide aluminium pan, 140mm returns with flange welded to inner return fitted over 1no 1100mm high 860mm wide aluminium pan 40mm returns and fixed in position with security fixings.

Rear pan externally finished 2 pack automotive paint RAL 7015 and internally finished White and lower back face fitted with 2no. fluorescent tubes.

Face pan and returns finished 2 pack automotive paint RAL 7015 and RAL 7046 selectively painted University logotype PMS 2602, PMS 123 and White. Lower section of face aperture cut with text and backed with Opal 050 acrylic.

Graphics

- 50mm Site name
- 60mm Building name

Note:

The sign should not be specified or procured without prior written consent from the Directorate of Estates. Illuminated signage may require advertising consent from the local planning department.



Sizes for UM06b & c	Width	Height	Depth
UM06b	1110mm	870mm	140mm
UM06c	1110mm	310mm	140mm

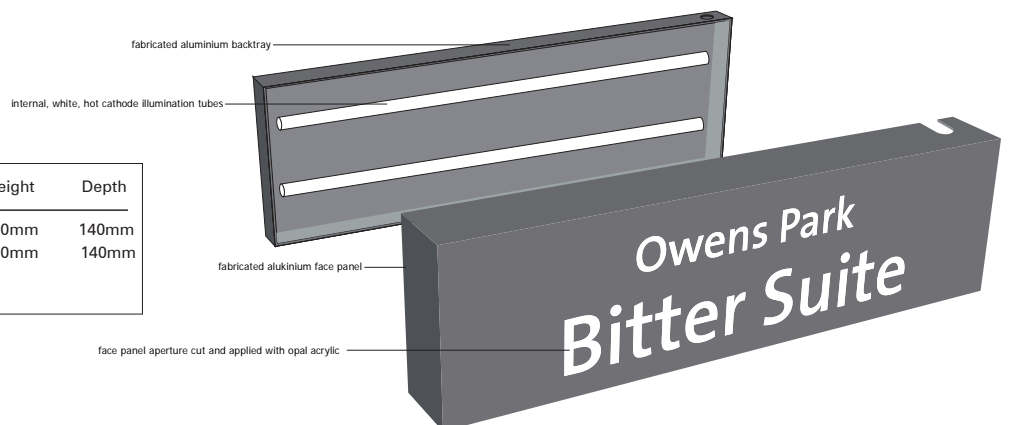

5.3 | Corporate Logo



A: Standard format for low level sign types

Reproduction
 The University’s corporate logo must be reproduced from digital format artwork supplied by the University only and should not be re-generated or adapted in any way by moving any of the elements.

ColourBlock
 background always appears purple(PMS 2602c) with white and yellow (PMS123c) text. Vertical University text colour can be either white or grey (PMS Cool grey8c) depending on background colour.

High Level
 Logo A second logo format has been adapted for high level use only. The text has been extended for clarity and to make it easier to read from a distance.

Note: This format of logo should never be used for any purpose other than individual letters.



B: Extended format for high level lettering only

A B C D E F **G** H I J K L M
N O P **Q** R S T U V W X Y Z
a b c d e f g h i j k l m
n o p q r s t u v w x y z
1 2 3 4 5 6 7 8 9 0

TheSans Plain

A B C D E F **G** H I J K L M
N O P **Q** R S T U V W X Y Z
a b c d e f g h i j k l m
n o p q r s t u v w x y z
1 2 3 4 5 6 7 8 9 0

TheSans Bold

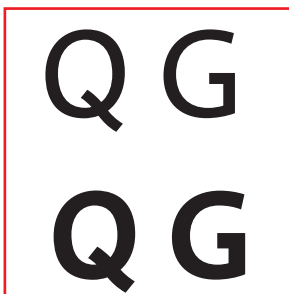

Substitute 'Q' and 'G'

Typeface

The typeface used for signage is TheSans Plain. Type will always be upper and lower case, written in title format, i.e. Capital for each main word.

Where text is to be highlighted TheSans Bold will be used.

All text will be ranged left, under no circumstances will text be arranged any different.

Colour

Text will always be White onto Scheiffergrau.

Symbols

Symbols should always accompany warning and information text wherever possible. These symbols have been designed specifically for the University and are displayed throughout these guidelines.

Note

All characters used on signage are from TheSans font, however it should be noted that where capital letters 'Q' and 'G' occur these should be substituted for characters created for The University of Manchester signage (shown opposite).

5 | Colours



University Purple
(Pantone 2602c)

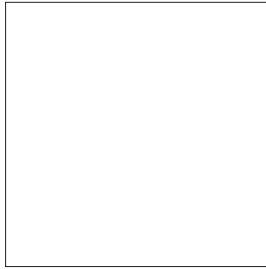

White



University Yellow
(Pantone 123c)



Scheiffergrau
(RAL 7015)



Telegrau 2
(RAL 7046)



Pantone 281



Pantone 376
(50%)



Pantone 299

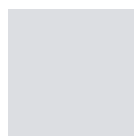

Pantone cool
grey 6 (40%)

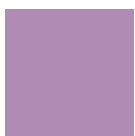

Pantone 259
(50%)



Pantone 485c



Pantone cool
grey 6

The University of Manchester logo comprises of two parts:-

a) 'Manchester 1824 tab device'

- University Purple
- University Yellow
- White

b) The University of Manchester namestyle:

- White

The primary colours of the signs will be Scheiffergrau for the main body background and Telegrau 2 as the background to the logo panel.

Primary colours palette:

- University Purple (Pantone 2602c)
- University Yellow (Pantone 123c)
- White
- Scheiffergrau (RAL 7015)
- Telegrau 2 (RAL 7046)

Supporting colours should only be used within the directional maps. These colours help in identifying footpaths, buildings, railway, roads, disabled access etc.

Supporting colours palette:

- Pantone 109 C
- Pantone 361 C
- Pantone Process Blue C
- Pantone 429 C

5.4 | Accessibility and the DDA

Car Park 'G'
Stopford Building
Biosciences
Visitor Centre
Whitworth Hall
Refectory

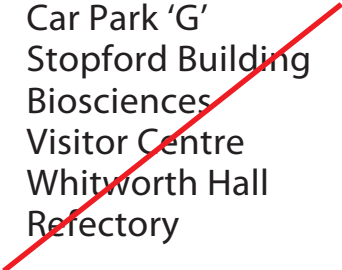

Normal line spacing. Ascenders and descenders merge together .

Car Park 'G'
Stopford Building
Biosciences
Visitor Centre
Whitworth Hall
Refectory

Correct line spacing. This improves legibility of each line of text

Fig. 1

The Disability Discrimination Act 1995

In 2001, part 4 of the DDA which relates to education, was amended by the Special Educational Needs and Disability Act. Part 4 set out a timetable of actions that needed to be undertaken to prevent unlawful discrimination to disabled people wishing to use or access the facilities and courses offered by educational establishments. This applies to students and the general public who, for example, might wish to attend an exhibition or performance in one of the University buildings.

The original Part 4 of the DDA covered 'physical features and changes' to premises comes into force in October 2004. Higher Education establishments will have until September 2005 to make any 'physical' adjustments. Therefore, signage, as a 'physical feature' will fall under the Act.

It is therefore in the interests of all service providers to ensure that their signage systems follow best practice as outlined in the Sign Design Guide (written by JMU and the Sign Design Society) and the new BS standard BS8300:2001. In developing this new corporate signage strategy for the University, a majority of the elements of best practice DDA have been incorporated. See illustrated examples commencing with figure 1 opposite.

5.4.4 | Accessibility and the DDA

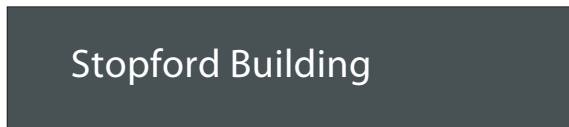

Fig. 11

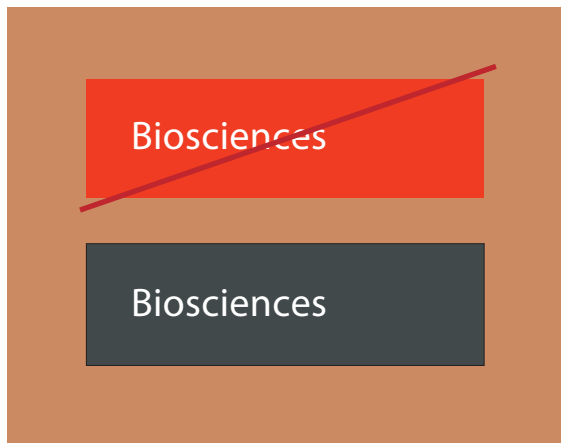

Fig. 12

Colour and Contrast

The efficiency of this sign system relies heavily on the ability of the user to detect, recognise and read the sign. Therefore contrast between letters or symbols, and their background is essential.

For external signage, light colours on a dark background are preferred to dark on a light.

Consideration should be given in determining colour combinations together with the background behind the signs. For example, many of the buildings within the University are red brick. Therefore a dark neutral colour with white text has been chosen to identify building names - Figure 12. If the use of a light coloured sign is chosen to be used on a light background, then consideration would have to be given to using a dark border on the sign to make it more visible.

This combination of white text on a dark sign, with a light background provides an optimum contrast.

~~Stopford Building
Biosciences~~

Stopford Building
Biosciences

Fig. 8

~~Stopford~~
Stopford

Fig. 9

Ea Ea

Fig. 10
Actual size: 15mm (left), 25mm (right).

Letterform

Typefaces preferred are sans serif faces, which are recommended for their legibility whilst the majority of serif typefaces prove difficult to read as shown in Figure 8. The Universities corporate sans serif typeface used for this project (TheSans) has been used for its modern, clean appearance.

Consideration should be given to the relationship between distance and legibility, ie. the amount of increased spacing between letters so that the text can easily be read from a reasonable distance. In this case, a 10% increase in letter-spacing has been used as shown in Figure 9.

The range of type sizes used in the University sign system has been kept to a minimum and is consistent between signs of the same size.

It is important that character size is relative to reading distance, and it is recommended that a minimum character size of 15-25mm is used for close to medium distance reading as shown in Figure 10, and symbols should be a minimum size of 100mm.

~~STOPFORD BUILDING
BIOSCIENCES~~

Stopford Building
Biosciences

Fig. 3



Fig. 4



Fig. 5



← Car Park 'G'
Stopford Building
Biosciences
Visitor Centre

Whitworth Hall →
Refectory

Fig. 6

~~↑ Car Park 'G'
← Stopford Building
← Biosciences
→ Visitor Centre~~

Fig. 7

Language and Arrows

Signs should use everyday words which the reader will understand and these should be used consistently and should relate to the user's needs.

Terminology should be consistent; ie. the words used on a directory sign should be identical to those found on a specific entrance sign. Users should be given enough information at any point to enable them to accomplish their current objective but information overload should be avoided.

For improved legibility, the first word of each of the key words should begin with a capital letter and continue in lower case and not all in capitals, as in Figure 3.

Currently the University uses arrows which are triangular in shape as in Figure 4. This type of arrow is considered unsatisfactory and is non-compliant with DDA recommendation, they lack 'real' direction, thus delivering a confusing message. Arrows recommended are those which have tails that are parallel with the main stem and not cut off at 90 degrees as shown in Figure 5.

On signs where a number of messages with directions are listed, the group of messages should be preceded by a single arrow as in Figure 6, rather than using individual arrows for each message as in Figure 7.

NOTE: To be read in conjunction with written specification attached

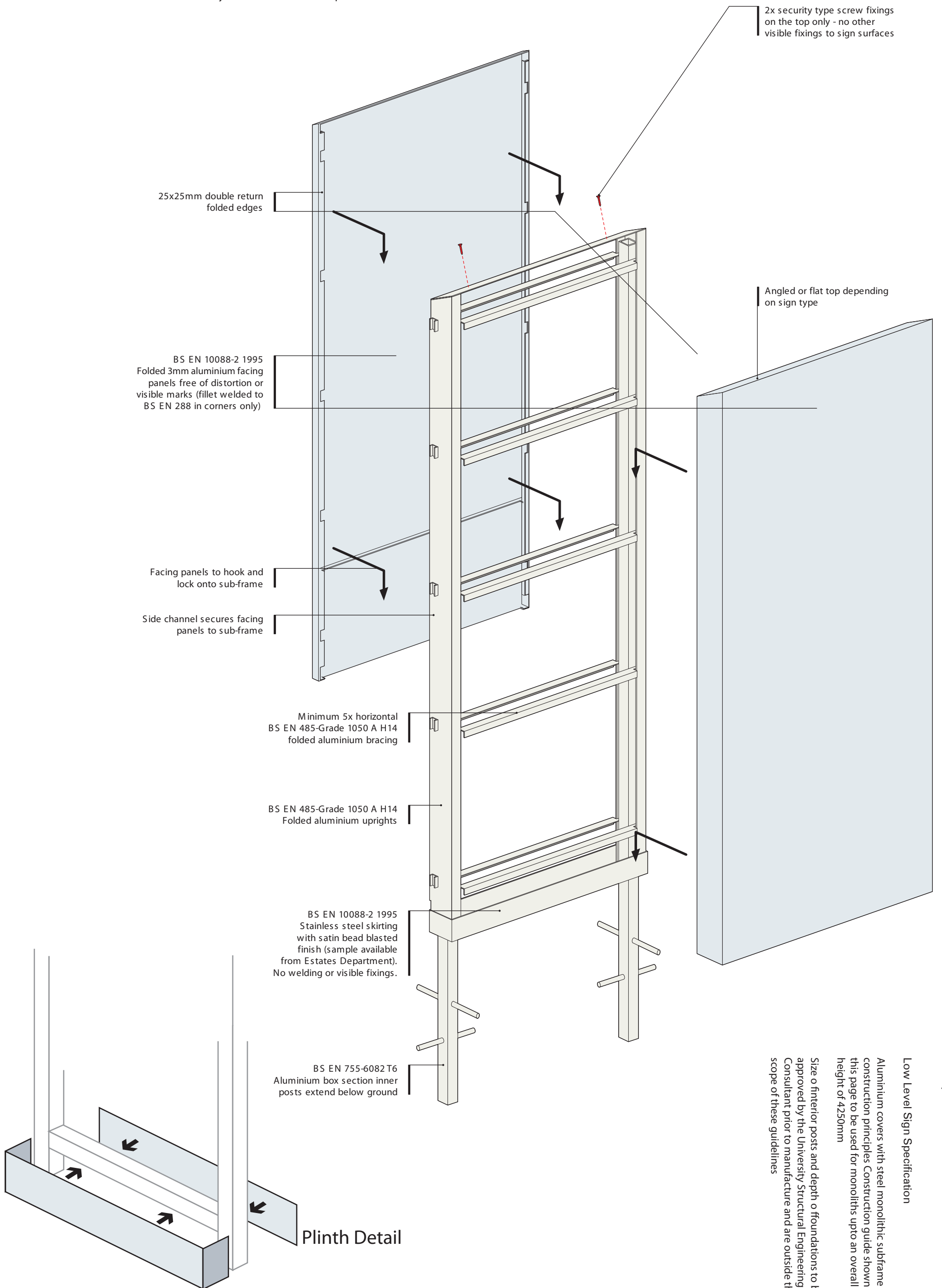

Low Level Sign Specification

Aluminium covers with steel monolithic subframe sign construction principles Construction guide shown on this page to be used for monoliths upto an overall height of 4250mm

Size of interior posts and depth of foundations to be approved by the University Structural Engineering Consultant prior to manufacture and are outside the scope of these guidelines

3.3 | Monolith Construction (A)

NOTE: To be read in conjunction with written specification attached

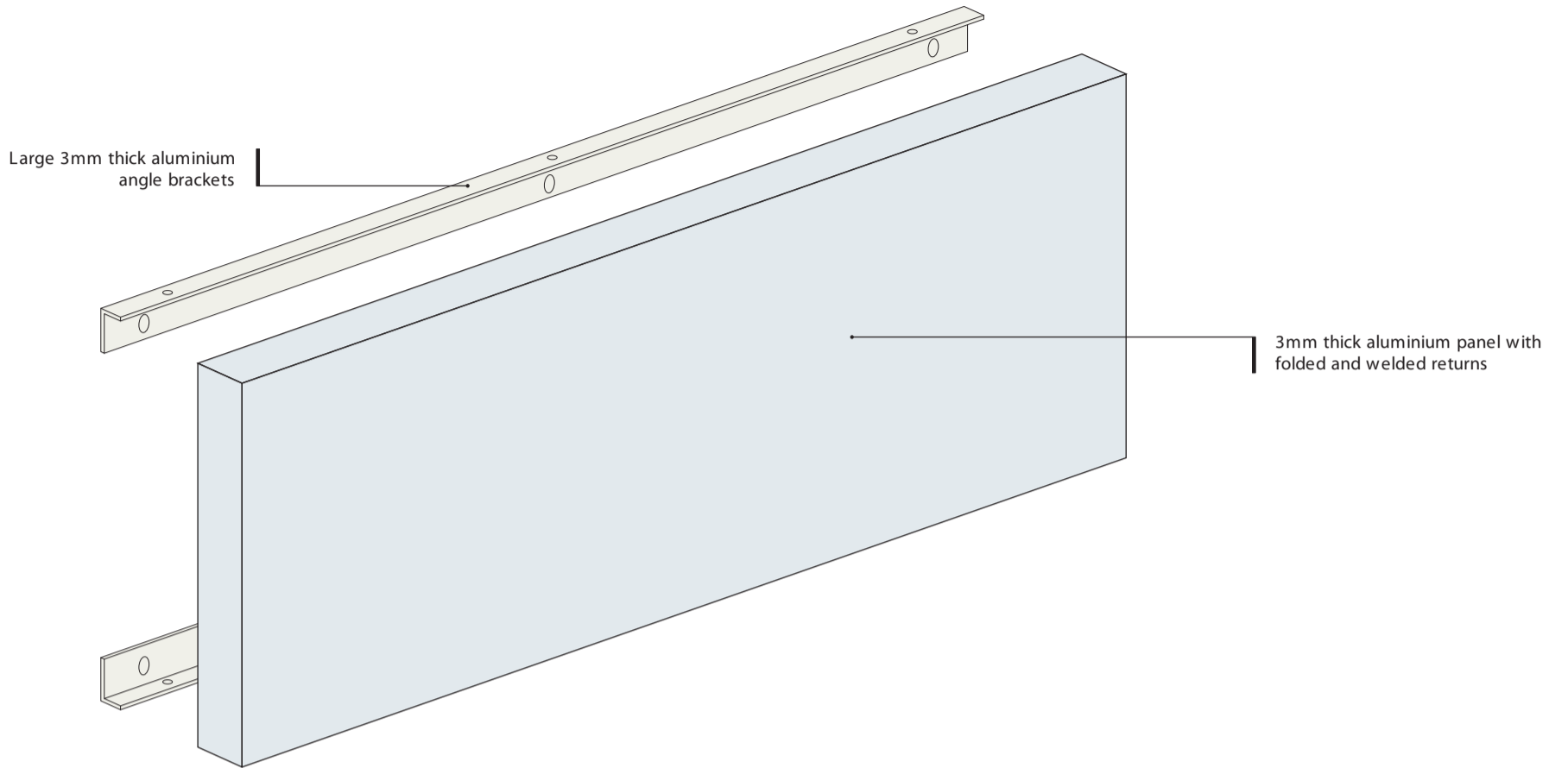

The University
of Manchester

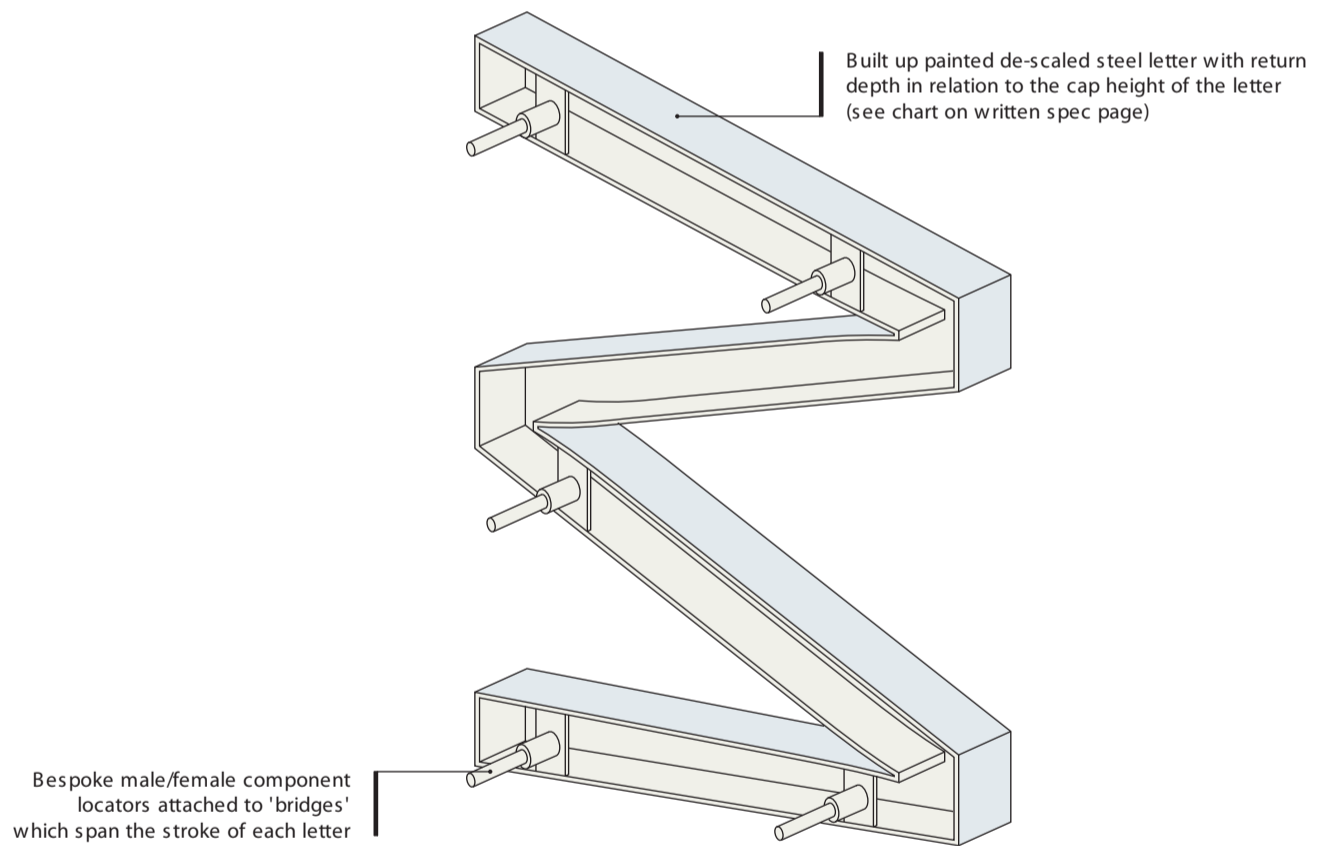

High Level Sign Specification
Painted aluminium tray and built up
de-scaled steel letters.
Sign construction principles

Number of fixings for each unit to be
agreed with the university prior to
installation and are outside the scope
of these guidelines

NOTE: To be read in conjunction with written specification attached

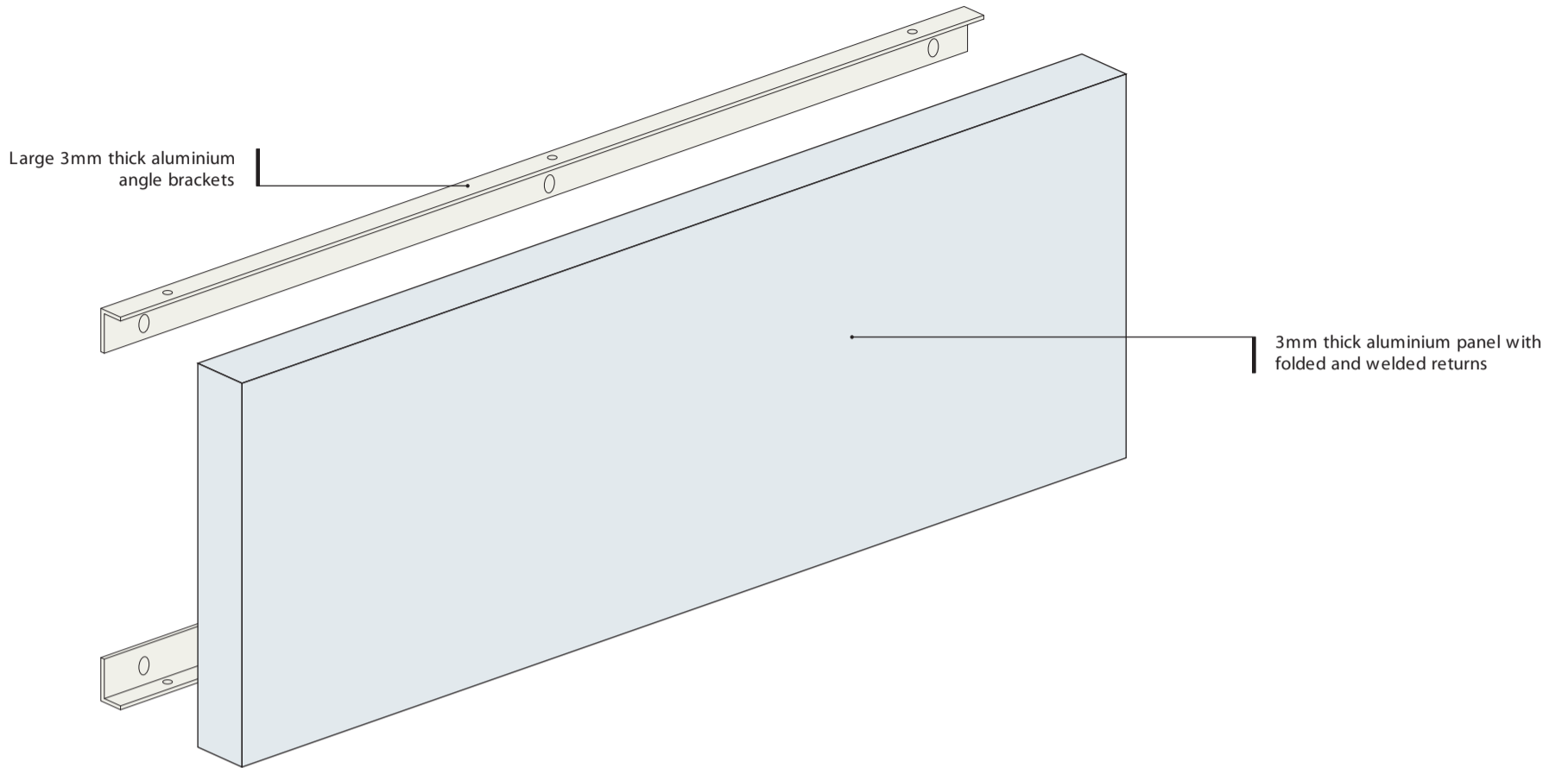

The University
of Manchester

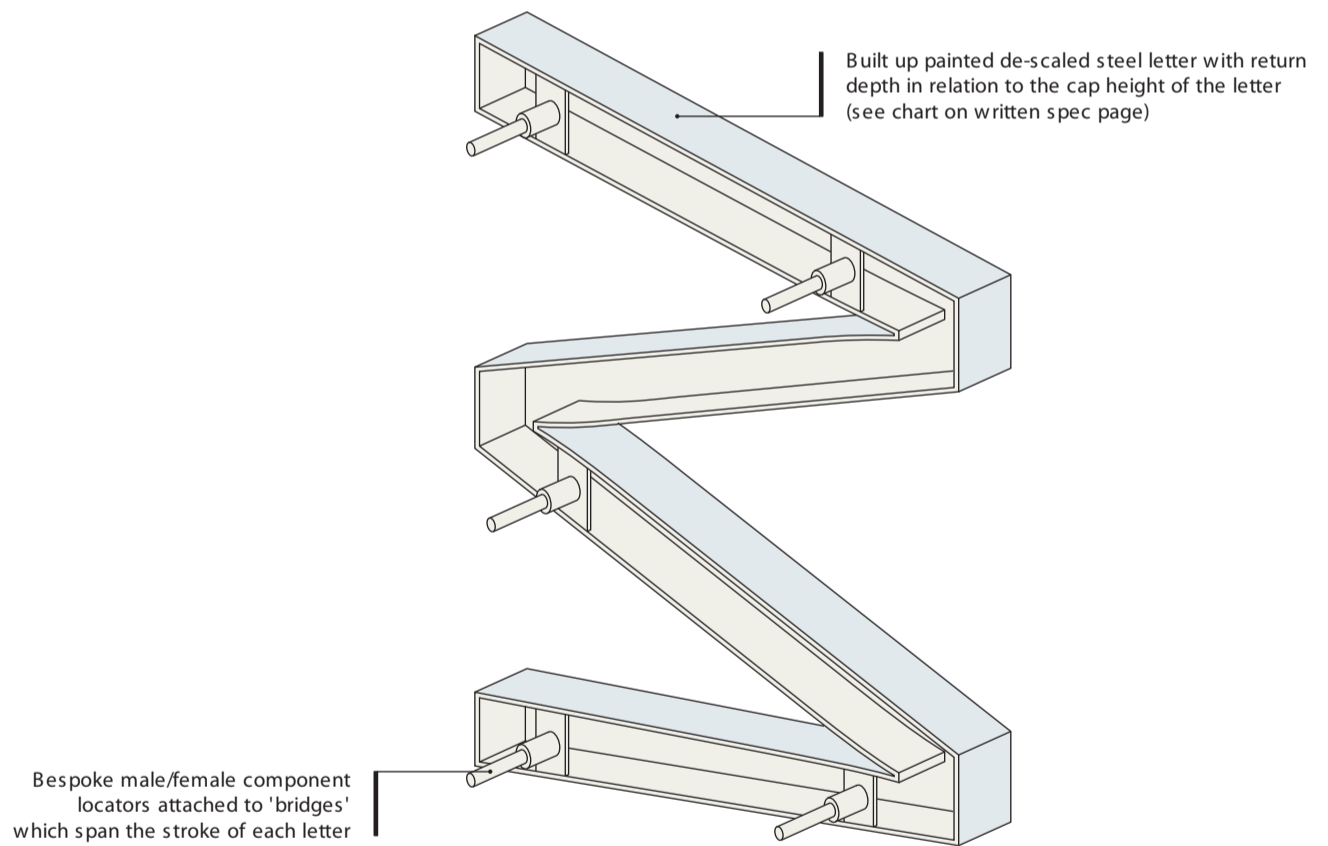

High Level Sign Specification
Painted aluminium tray and built up
de-scaled steel letters.
Sign construction principles

Number of fixings for each unit to be
agreed with the university prior to
installation and are outside the scope
of these guidelines

NOTE: To be read in conjunction with written specification attached

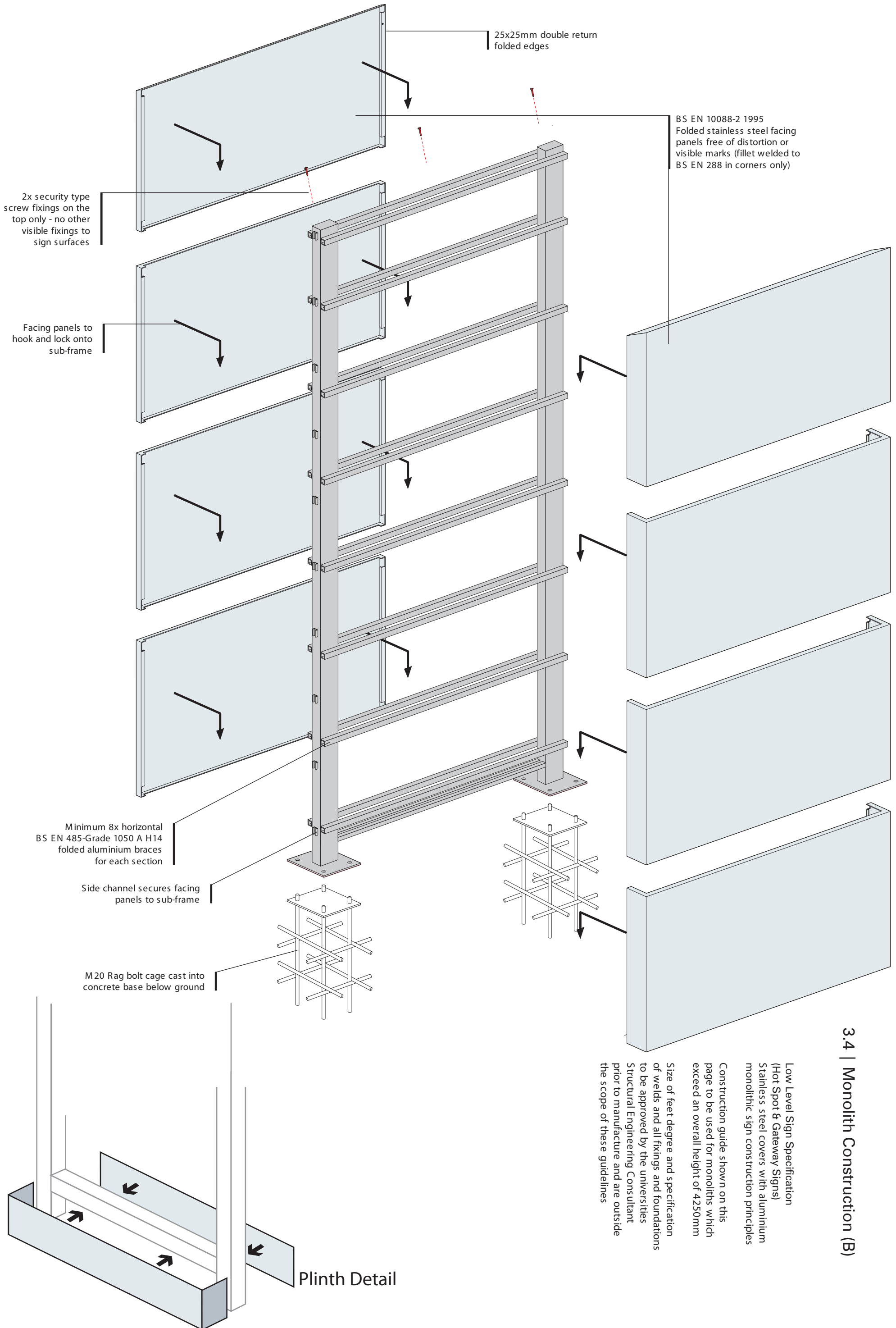

3.4 | Monolith Construction (B)

Low Level Sign Specification
(Hot Spot & Gateway Signs)
Stainless steel covers with aluminium monolithic sign construction principles

Construction guide shown on this page to be used for monoliths which exceed an overall height of 4250mm

Size of feet degree and specification of welds and all fixings and foundations to be approved by the universities Structural Engineering Consultant prior to manufacture and are outside the scope of these guidelines

High Level Signs (after)

Project N°: 4063



Sign 11 & 12
(Tray Sign and Letters)
Aquatics Centre Multi-story Car Park



Sign 13
(Tray Sign and Letters)
Crawford House



Sign 16
(Tray Sign and Letters)
Chemistry Building



Sign 17
(Tray Sign and Letters)
Schuster Laboratory



Sign 18
(Tray Sign and Letters)
Stopford Building



Sign 23
(Tray Sign and Letters)
John Rylands Library

High Level Signs (after)

Project N°: 4063



Sign 1
(Tray Sign Type and Letters)
Main Building



Sign 2, illuminated by others
(Tray Sign Type and Letters)
Chandos Hall



Sign 3, illuminated by others
(Tray Sign Type and Letters)
Mathematics Building North



Sign 4, illuminated by others
(Tray Sign Type and Letters)
Mathematics Building South



Sign 5, illuminated by others
(Tray Sign Type and Letters)
Faraday Building



Sign 9
(Tray Sign Type and Letters)
Oddfellows Hall

High Level Signs (after)

Project N°: 4063



Sign 24
Tray Sign and Letters
Dental School



Sign 25
Tray Sign and Letters
Dental School



Sign 27 (illuminated by others)
Tray Sign and Letters
Manchester Business School



Sign 28
Tray Sign and Letters
Precinct Shopping Centre South



Sign 29 a/b
Tray Sign and two sets of Letters
Precinct Shopping Centre North



Sign 30
Tray Sign and Letters
Faraday Building

Directional Signs



UM-10

Directional Wall Mounted Sign

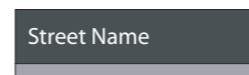

Street Name (wall mounted)

UM-11



UM-11b

Street Name (post mounted)



Pedestrian Directional

UM-07

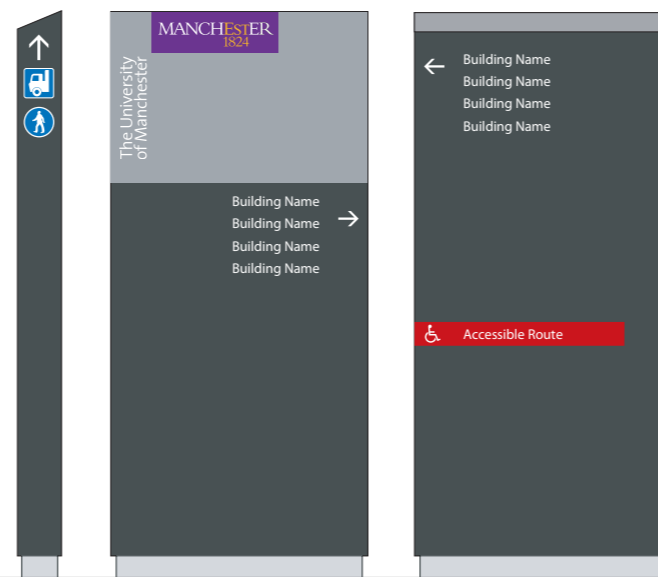

Pedestrian / Vehicular Directional

UM-08



Vehicular Directional

UM-09

UM-17

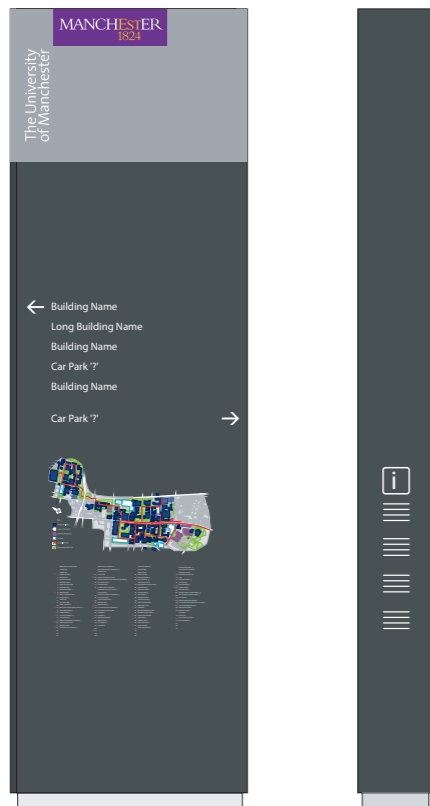

Hot Spot Monolith



Camp Map Monolith



UM-18a

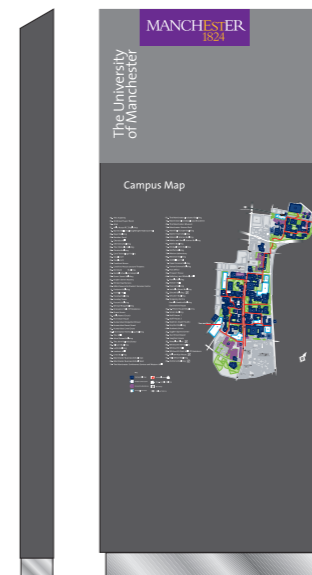

UM-18b



UM-18c

Campus Map Monolith



UM-19

Campus Map Wall Mounted Tray

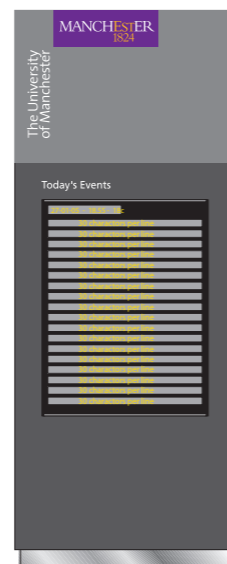

UM-20

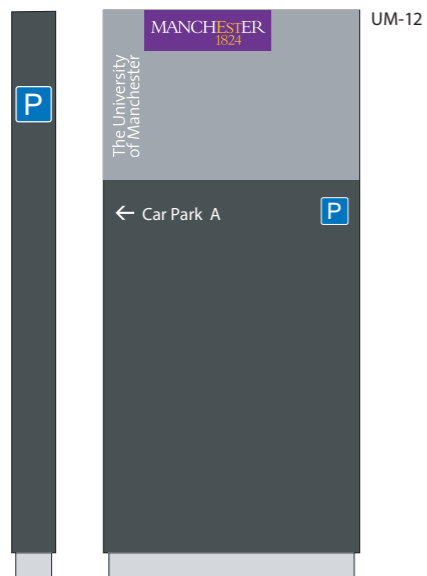

Directional Monolith (Car Park)

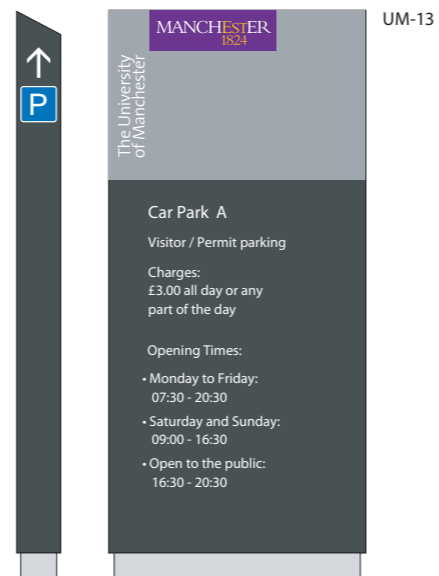

Entrance Monolith (Car Park)

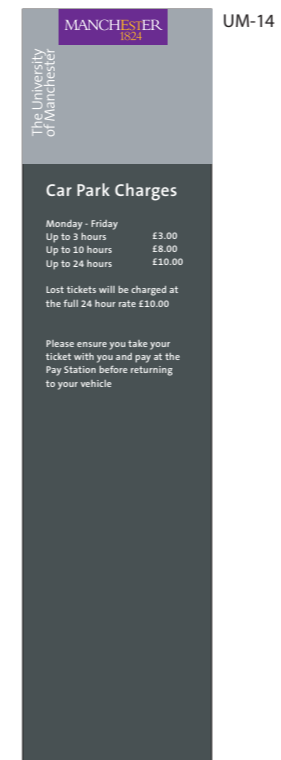

UM-14



UM14b

UM-14b

1.1 University Identification

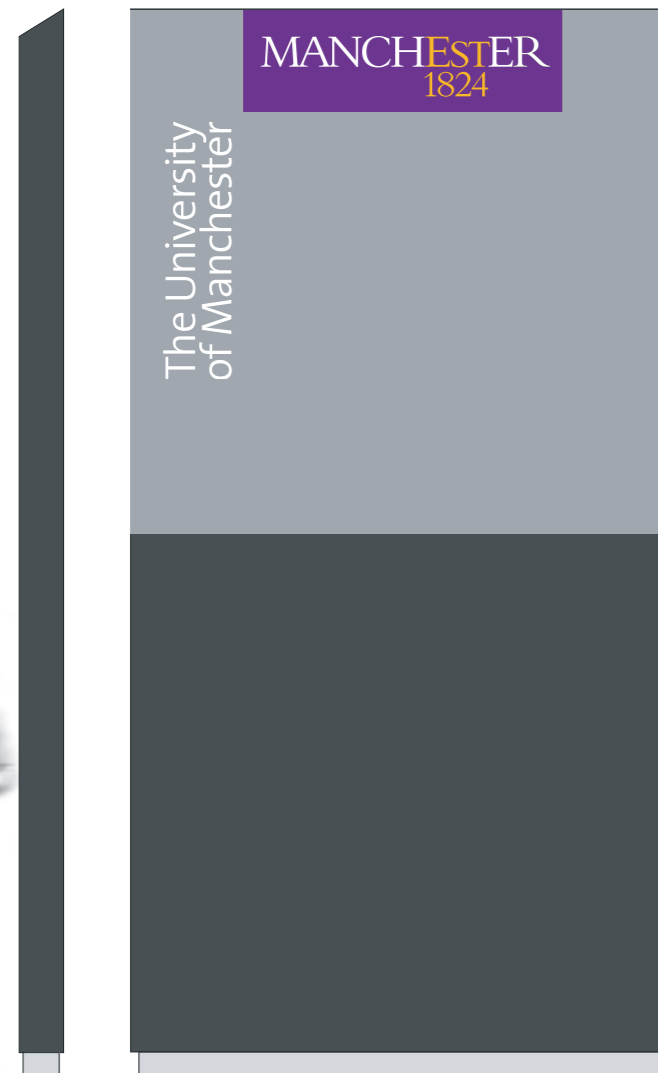

Gateway Monolith

UM-01

1.2 Building Identification



UM-03

Building Name Wall Mounted Tray

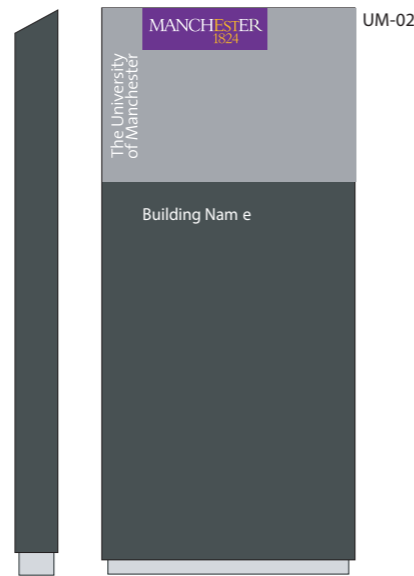

UM-02

Building Name Monolith

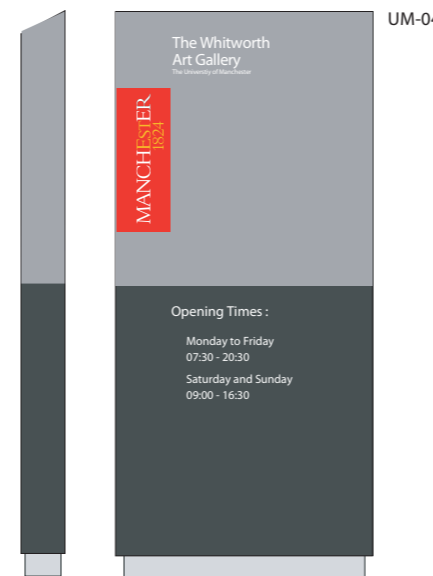

UM-04

Sub Brand Monolith

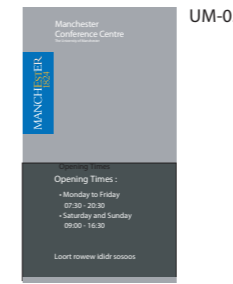

UM-05

Sub Brand Wall Mounted Tray

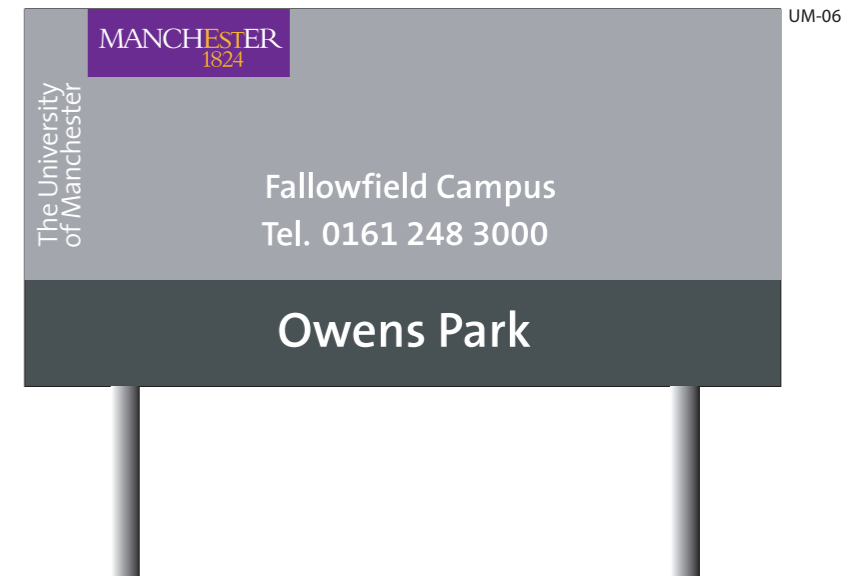

UM-06



1.1 University Identification

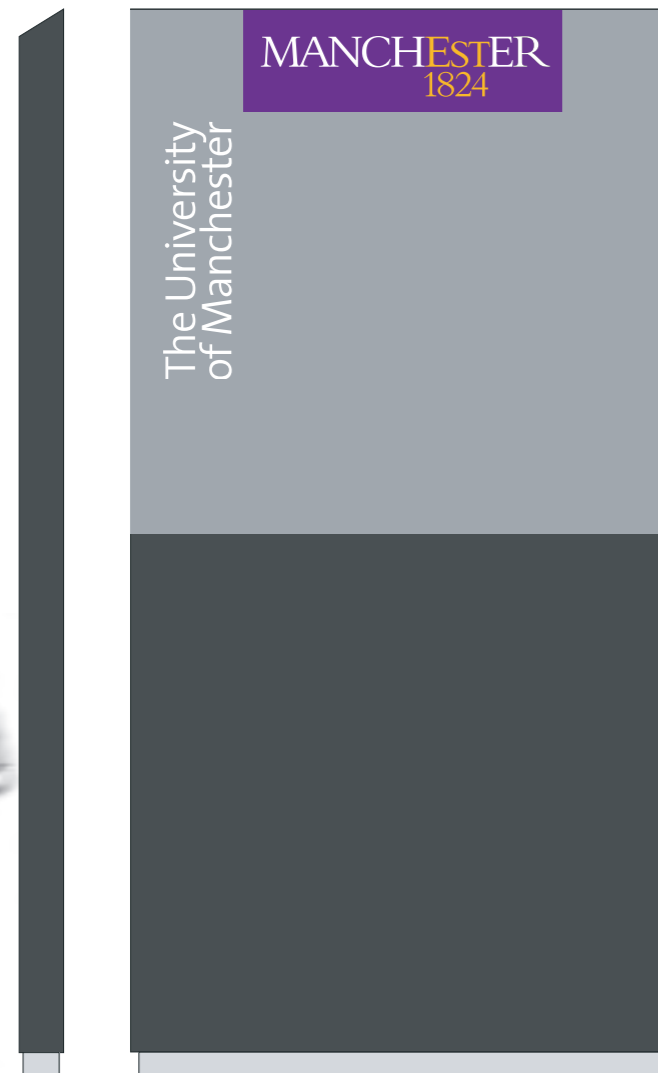

Gateway Monolith

UM-01

1.2 Building Identification



UM-03

Building Name Wall Mounted Tray

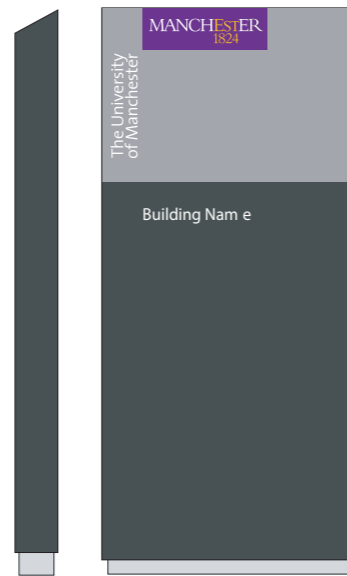

UM-02

Building Name Monolith



UM-04

Sub Brand Monolith

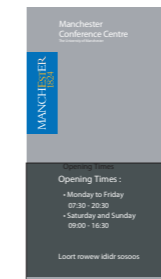

UM-05

Sub Brand Wall Mounted Tray



UM-06

UM-04 & UM-05
other Sub brands

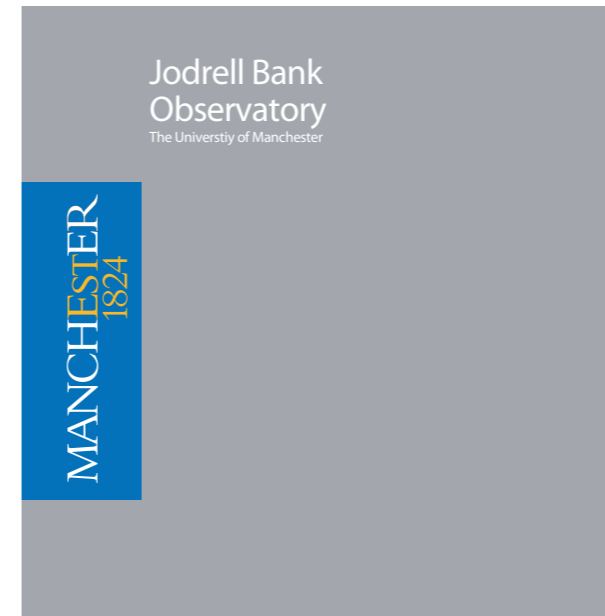
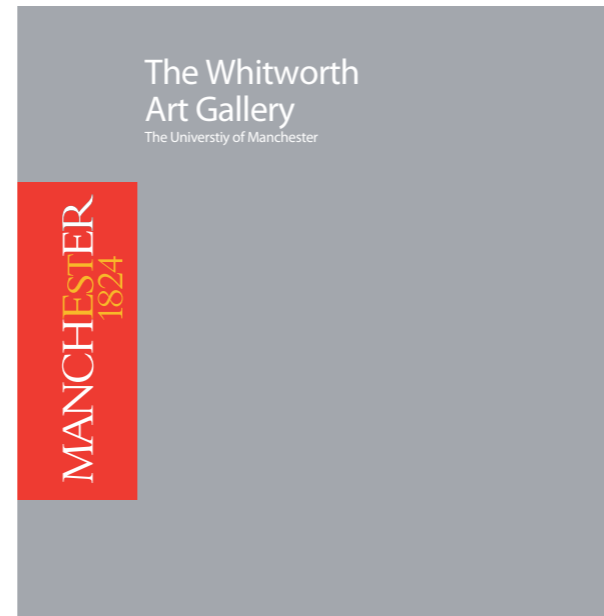

These are examples of the University Sub-brands. Further information is available from the communicating department.

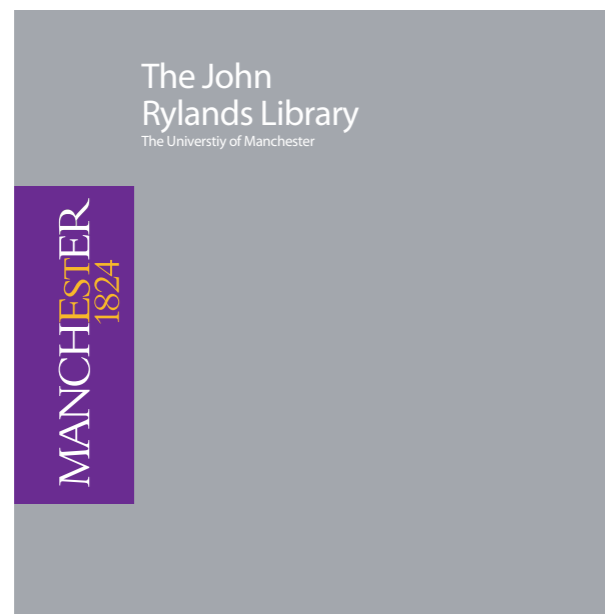

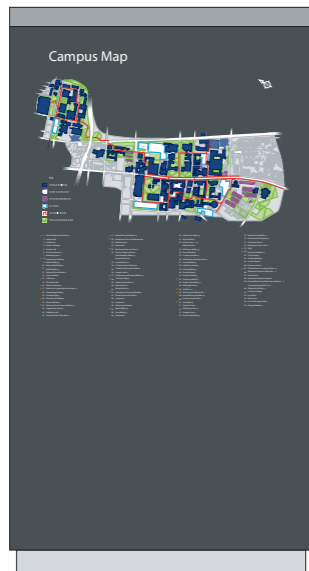

Campus Map Monolith
(map orientation position A)



Campus Map Monolith
(map orientation position B)



Campus Map Monolith
(map orientation position C)



Campus Map Monolith
(map orientation position D)

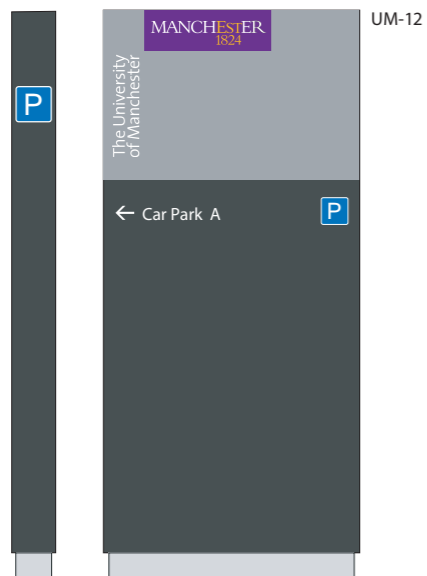

Directional Monolith (Car Park)

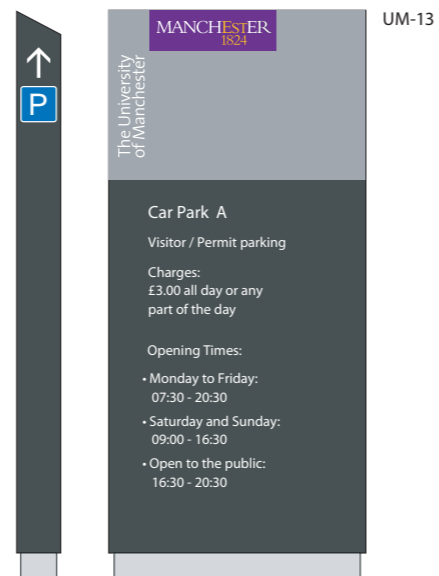

Entrance Monolith (Car Park)

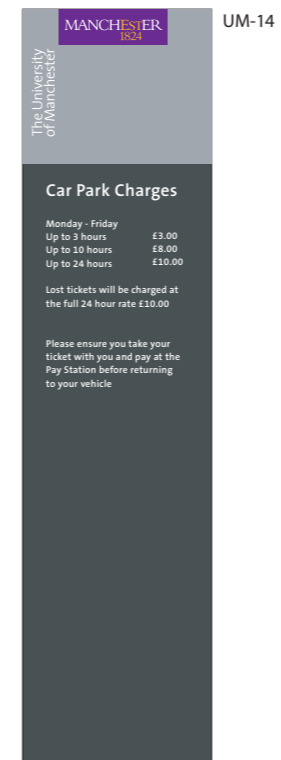

UM-14



UM14b

UM-14b

Directional Signs



UM-10

Directional Wall Mounted Sign

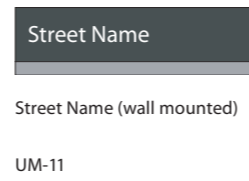

Street Name (wall mounted)

UM-11

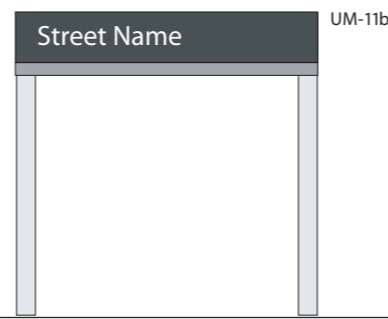

UM-11b

Street Name (post mounted)



UM-07

Pedestrian Directional

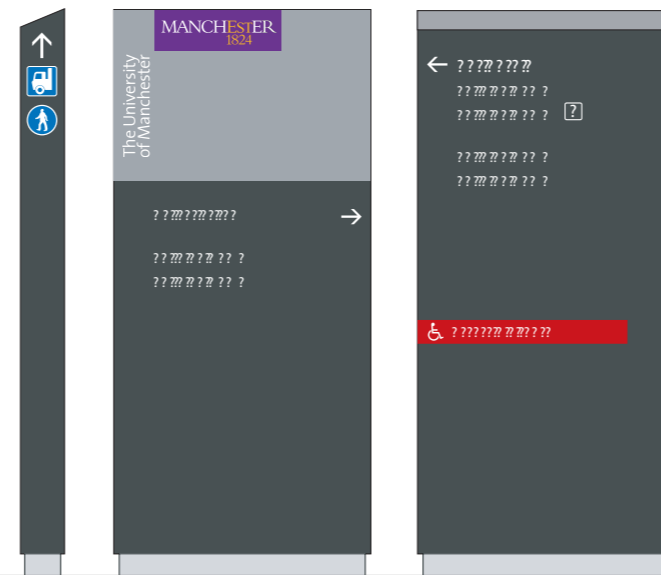

UM-08

Pedestrian / Vehicular Directional

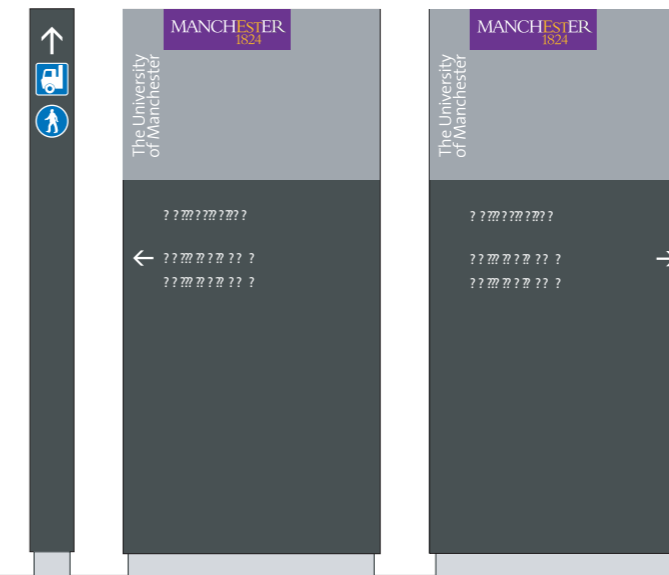

UM-09

Vehicular Directional

UM-16

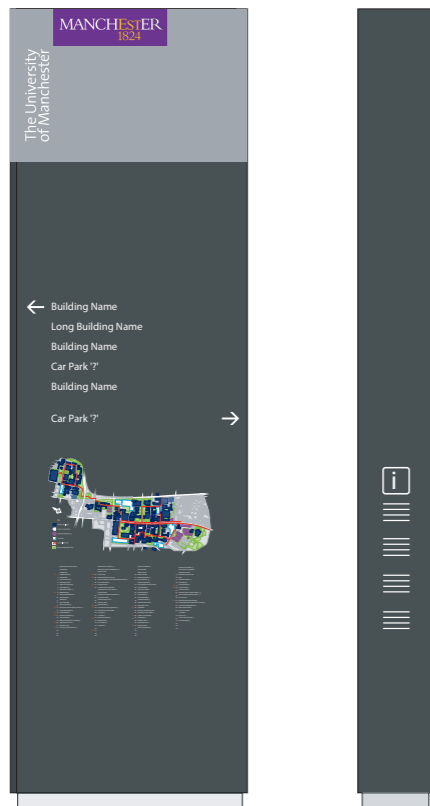

Hot Spot Monolith



Camp Map Monolith



UM-18a

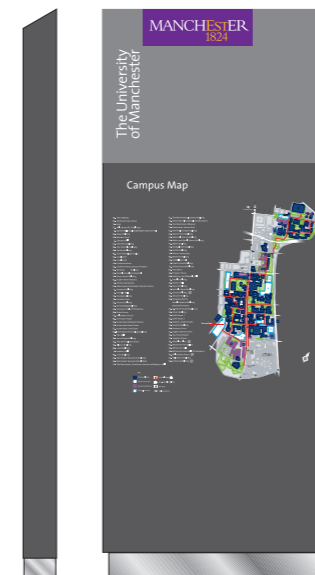

UM-18b

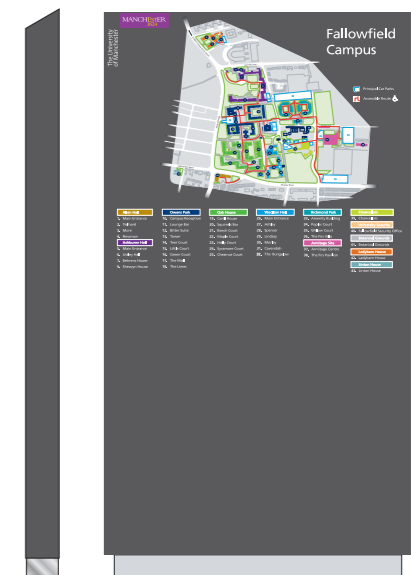

UM-18c

Campus Map Monolith



UM-19

Campus Map Wall Mounted Tray

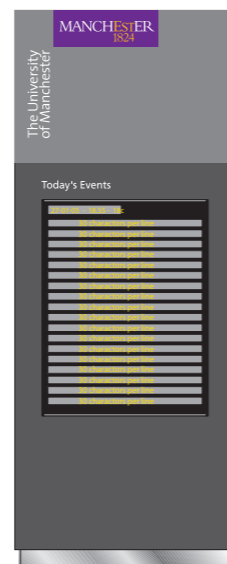

UM-20

UM-04 & UM-05
other Sub brands

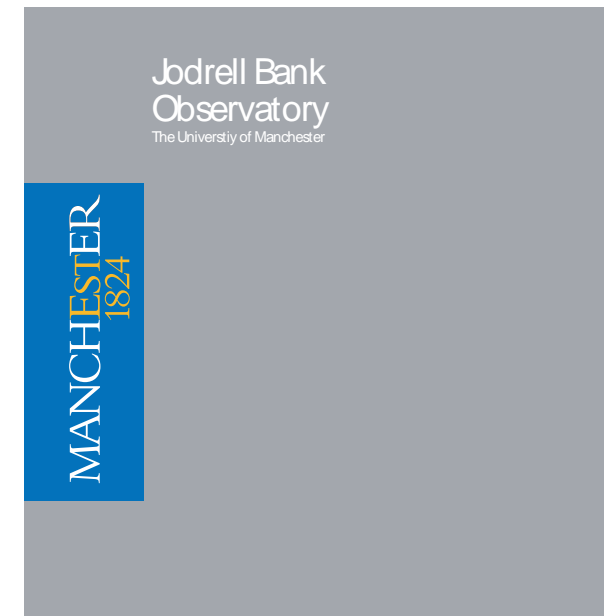
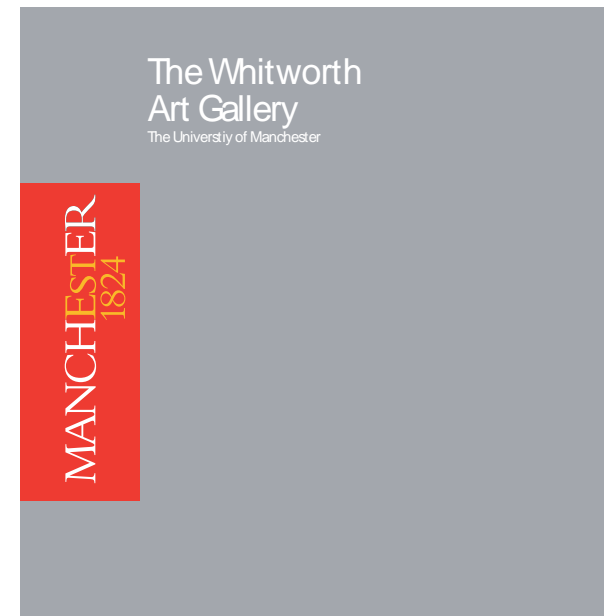

These are the University's sub-brands
further information can be obtained
from The Communications Department

