

Creda

C150E

Installation & User

Instructions

You must read these instructions prior to using the appliance and retain them for future reference.



For more information on our exciting product range ring
Creda Answer Centre 08701 54 64 74

OR



Visit us on the **NET** at
<http://www.creda.co.uk>

Our site invites you to make use of our **interactive cookbook** and **product selector**.
Feel free to **browse our product range** to see what's **bubbling away** at the moment
or to **ask for help** on our products and services



Creda

General Domestic Appliances Ltd. Morley Way Peterborough PE2 9JB
Creda Answer Centre 08701 54 64 74
Web <http://www.creda.co.uk>

It may be necessary from time to time to change the specification outlined in this booklet
without notice. Any change which is made will not affect your statutory rights.

Contents

Introduction	4
Installation	5-6
For your Safety – Always	7
For your Safety – Never	8
Features	9
Control Panel	10
Hotplates General Information Notes	11-12
Temperature Conversion Chart	13
Grill	14
Grill Chart	15
Oven	16
Oven Cookery Notes	17-19
Care and Cleaning	20-21
Cooking Results Not Satisfactory	22
Something Wrong with your Cooker	23
Key Contacts	Back Cover

Introduction

Your new appliance is guaranteed* and will give lasting service. This guarantee is only applicable if the appliance has been installed in accordance with the installation instructions detailed in this booklet.

To help make best use of your cooking equipment, please read this booklet carefully.

The cooker is designed specifically for domestic use and responsibility will not be accepted for use in any other installation.

**When the cooker is first used an odour may be emitted,
this will cease after a period of use**

When first using the cooker ensure that the room is well ventilated (e.g. open a window or use an extractor fan) and that persons who may be sensitive to the odour avoid any fumes. It is suggested that any pets be removed from the room until the smell has ceased. This odour is due to temporary finish on oven liners and elements and also any moisture absorbed by the insulation.

*** The guarantee is subject to the provisions that the appliance:**

- (a) Has been used solely in accordance with the Users Instruction Book.**
- (b) Has been properly connected to a suitable supply voltage as stated on the rating plate attached to this equipment.**
- (c) Has not been subjected to misuse or accident or been modified or repaired by any person other than the authorised employee or agent.**
- (d) Has been correctly installed.**

DISPOSAL OF YOUR PRODUCT

To minimise the risk of injury to children please dispose of your product carefully and safely. Remove all doors and lids. Remove the mains cable (where fitted) by cutting off flush with the appliance and always ensure that no plug is left in a condition where it could be connected to the electricity supply.

To help the environment, Local Authority instructions should be followed for the disposal of your product.

This appliance conforms to the following EEC Directives:

Electromagnetic Compatibility
89/336/EEC
92/31/EEC
93/68/EEC

Low Voltage Equipment
73/23/EEC
93/68/EEC



Installation

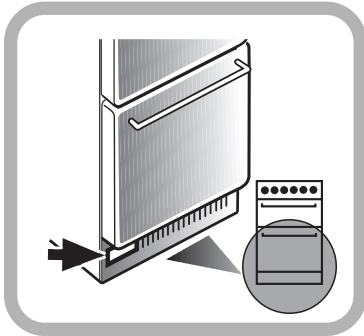

WARNING – THIS APPLIANCE MUST BE EARTHED.

Your cooker should have been checked to ensure that the voltage corresponds with your supply voltage, this is stated on the **rating plate**, which is situated on the rear panel. The cooker must be connected by a competent person eg. (NICEIC registered contractor) to suitable double-pole control unit with a minimum rating of 32A and a minimum contact clearance of 3mm, which should be fitted adjacent to the cooker, in accordance with IEE regulations.

The power supply cable should conform to B.S.6004 with a conductor size of 6mm² minimum.

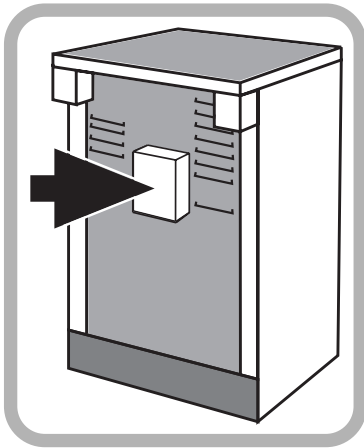

The control unit should be easily accessible in the event of an emergency, but must be within 2 metres of and not directly above an appliance.

This appliance conforms to EN 55014 regarding suppression of radio and television interference.

Access to the **mains terminals** is gained by removing the **rear access cover**.

The mains cable must pass through the cable clamp adjacent to the terminal block. Sufficient cable should be used to allow the cooker to be pulled out for servicing.

Ensure that the mains cable is routed away from any brackets affixed to the rear panel and is not trapped to the rear wall when pushing the cooker into position between cabinets.

Siting the Cooker

The cooker is designed to fit between kitchen cabinets spaced 500mm apart. The space either side need only be sufficient to allow withdrawal of the cooker for servicing. It can be used with cabinets one side or both as well as in an angled corner setting. It can also be used free standing.

This cooker is a Type X appliance, as such adjacent side walls which project above hob level, must not be nearer to the cooker than 150mm and should be protected by heat resistant material. Any overhanging surface or cooker hood should not be nearer than 650mm.

The height of the cooker can be adjusted by means of adjustable feet in the plinth (900mm - 915mm). Adjust the feet by tilting the cooker from the side. Then install the cooker into position.

Moving the Cooker

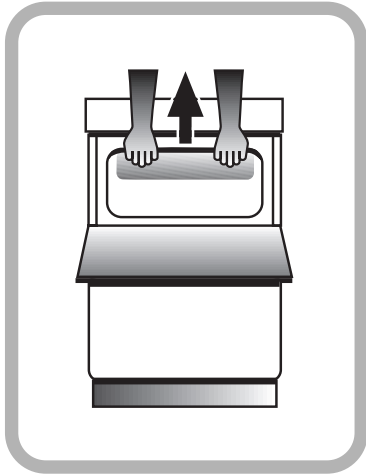

Before moving your cooker, switch off at the cooker control unit, ensure that it is cool.

Movement of your cooker is most easily achieved by lifting the front as follows:
Open the grill door sufficiently to allow a comfortable grip on the underside front edge of the oven roof, avoiding any grill elements.

Note: Take care in moving the cooker as it is heavy. Take care to ensure that any floor covering is not damaged.

Splash Panel Kit (Wall Mounted)

Splashplate optional, apply to Parts Department (see Back Cover for contact number.)

Safety Information

**When used properly your appliance is completely safe but as with any electrical product there are certain precautions that must be observed.
PLEASE READ THE PRECAUTIONS BELOW BEFORE USING YOUR APPLIANCE.**

Always

- Remove all packing from the appliance before switching on for the first time.
- Understand the controls prior to using the appliance.
- Keep children away from the appliance when cooking as the surfaces will get extremely hot during and after use.
- Turn controls **off** when not in use.
- Stand back when opening an oven door to allow any build up of steam or heat to disperse.
- Always use dry good quality oven gloves when removing items from the oven/grill.
- Always place pans centrally over the hotplate making sure handles are kept away from the edge of the hob and cannot become heated by other hotplates or pans.
- Always take care to avoid heat or steam burns when operating the controls.
- Always turn off the electricity supply at the wall switch and allow the appliance to cool before cleaning (or changing an oven lamp if fitted).
- Always make sure the shelves are in the correct position before switching on the oven or grill.
- Always keep the oven/grill door closed when the appliance is not in use.
- Always keep the appliance clean as a build up of grease or fat from cooking can cause a fire.
- Always follow the basic principles of food handling and hygiene to prevent the possibility of bacterial growth.
- Always keep ventilation slots clear of obstructions.
- Always refer servicing to a qualified appliance service engineer.
- Always take care when removing items from the grill compartment when the lower oven is in use as the contents will be hot
- Always turn off the electricity supply to the appliance at the wall switch should any glass panel (if fitted) crack or shatter and then **DO NOT USE THE APPLIANCE** until repaired.
- During use, the oven becomes hot. Care should be taken to avoid touching heating elements inside the oven.

Safety Information

Never

- Never stare at Halogen heating units
- Never leave children unsupervised where a cooking appliance is installed as all surfaces will be hot during and after its use.
- Never allow anyone to sit or stand on any part of the appliance.
- Never store items above the appliance that children may attempt to reach.
- Never leave anything on the hob surface when unattended and not in use.
- Never remove the oven shelves whilst the oven is hot.
- Never heat up unopened food containers as pressure can build up causing the container to burst.
- Never store chemicals/food stuffs or pressurised containers in or on the appliance, or in cabinets immediately above or next to the appliance.
- Never place flammable or plastic items on or near the hob.
- Never fill a deep fat frying pan more than 1/3 full of oil, or use a lid.
DO NOT LEAVE DEEP FAT FRYING PANS UNATTENDED WHILE COOKING.
- Never use the appliance as a room heater.
- Never use the grill to warm plates.
- Never dry any items on either the hob or oven doors.
- Never install the appliance next to curtains or other soft furnishings.
- Never operate the grill with the grill door closed as this will cause the appliance to over heat.

SAFETY ADVICE IN CASE OF A CHIP-PAN FIRE

In the event of a chip pan fire or any other pan fire.

1. TURN OFF THE COOKER APPLIANCE AT THE WALL SWITCH.
2. COVER THE PAN WITH A FIRE BLANKET OR DAMP CLOTH, this will smother the flames and extinguish the fire.
3. LEAVE THE PAN TO COOL FOR AT LEAST 60 MINUTES BEFORE MOVING IT. Injuries are often caused by picking up a hot pan and rushing outside with it.

NEVER USE A FIRE EXTINGUISHER TO PUT OUT A PAN FIRE as the force of the extinguisher is likely to tip the pan over.
Never use water to extinguish oil or fat fires.

Features

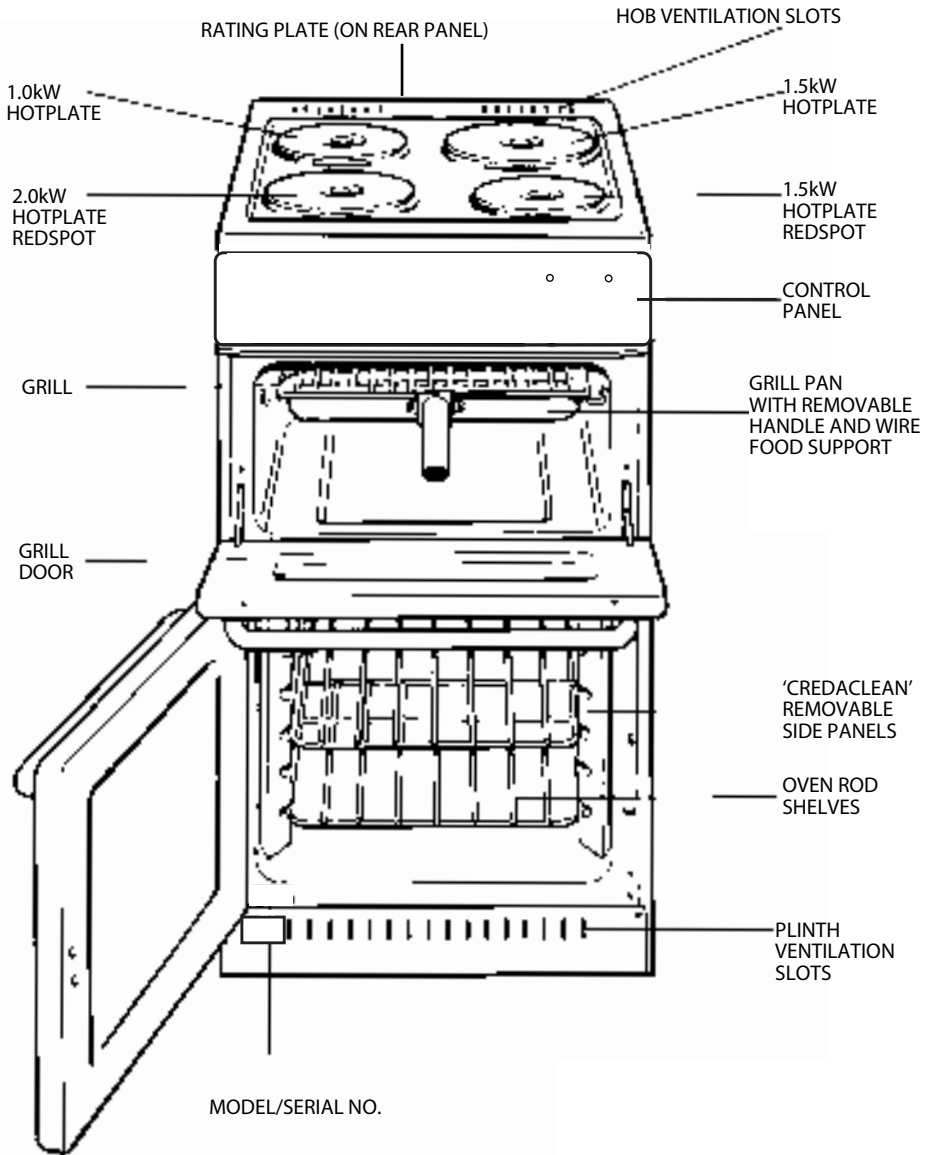

Control Panel

GRILL
PILOT
LIGHT

OVEN
PILOT
LIGHT

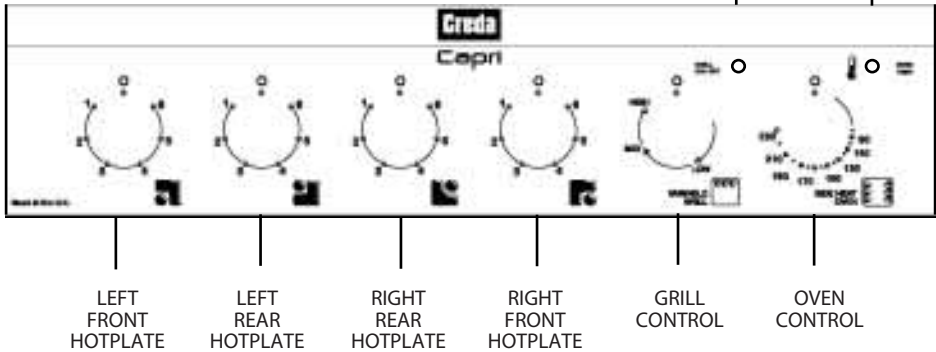

Control Knobs

The knobs for the grill and hotplates can be rotated in either direction to provide variable heat control, the oven knob can only be rotated clockwise from the **off** position.

Note: Always ensure that all controls are in the OFF position, when appliance is not in use.

Operating the control when the grill is in use

In common with all cookers having controls sited above the grill compartment, care must be taken when setting the controls, due to hot air being emitted from the grill compartment.

Hotplates General Information Notes

Note:

Under no circumstances should the hob be used with aluminium foil in contact with the hob surface.

Use of Hotplates

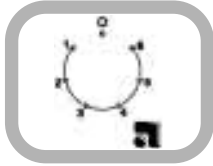

The controls set the hotplates at six pre-set power levels. Each control can be used to select one of six temperature settings from a minimum at position 1 to a maximum at position 6, the redspot hotplates heat up more rapidly to give faster boiling.

Control Settings Guide

This table is provided only as a guide – settings also depend on the type of pan used and the quality of food.

Knob Position	Type of food
1	To melt butter, chocolate, etc.
1 or 2	To heat food gently. To keep small amounts of water simmering. To heat sauces, containing egg yolks and butter, To simmer: stews, meat, fish, vegetables, fruit.
3	To heat solid and liquid foods. Keep water boiling. Thaw frozen vegetables. Make 2-3 egg omelettes.
4 or 5	To cook foods, just above simmering. To maintain 'rolling' boil for preserve making.
5 or 6	To seal meat and fry fish.
6	Frying potatoes. Bringing water to the boil. Deep fat frying. Dissolve sugar for preserve making.

Safety requirements for deep fat frying

1. Use a deep pan, large enough to completely cover the appropriate heating area.
2. Never fill the pan more than one-third full of oil.
3. Never leave oil or fat unattended during the heating or cooking period.
4. Never try to fry too much food at a time, especially frozen food. This only lowers the temperature of the oil or fat too much, resulting in greasy food.
5. Always dry food thoroughly before frying, and lower it slowly into the hot oil or fat. Frozen foods, in particular, will cause frothing and spitting, if added too quickly.
6. Never heat fat, or fry, with a lid on the pan.
7. Keep the outside of the pan clean and free from streaks of oil or fat.

Hob General Information

CHOICE OF UTENSILS

Every Electric Hob deserves the right choice of utensils. We recommend for optimum performance the use of good quality utensils.

PANS SHOULD NOT



Be concave (bowed in)



Be convex (bowed out)



Be rimmed



Be deeply ridged



But essentially Flat

Always ✓	Never ✗
<ul style="list-style-type: none"> ● Use good quality flat-based cookware on all electric heat sources. ● Ensure pans have clean, dry bases before use. ● Ensure pans match size of heating area. ● Remember good quality pans retain heat well, so generally only a low or medium heat is necessary. ● Ensure pan handles are positioned safely and away from heat sources. ● Lift pans, do not drag. ● Use pan lids except when frying. ● Deal with spillage immediately but with care. 	<ul style="list-style-type: none"> ● Use gauze, metal pan diffusers, asbestos mats and stands e.g. Wok stands – they can cause overheating. ● Use utensils with skirts or rims e.g. buckets and some kettles. ● Use badly dented or distorted pans. ● Leave an element switched on when not cooking. ● Cook food directly on the hot-plate. ● Drag or slide utensils across the hob surface. ● Place large preserving pans or fish kettles across two hot-plates. ● Place plastic vessels or utensils on a hot hob. ● Use the hob as an area for storage



Always place pans centrally on the hotplate



Temperature Conversion Chart

Gas Mark	°F	Main Convection Oven	Top Convection Oven	Main Fan Oven
1/2	250	120	110	100
1	275	140	130	120
2	300	150	140	130
3	325	160	150	140
4	350	180	170	160
5	375	190	180	170
6	400	200	190	180
7	425	220	210	200
8	450	–	220	210
9	475	–	–	220

Grill

Setting the Grill



CAUTION – ACCESSIBLE PARTS WILL BECOME HOT WHEN THE GRILL IS IN USE. CHILDREN SHOULD BE KEPT AWAY. GRILLING SHOULD NOT BE UNDERTAKEN WITH THE GRILL DOOR CLOSED.

Never: line the grill pan with aluminium foil. Preheat the grill at setting HIGH for approximately 5 minutes. The grill pilot light will illuminate to show the grill is switched on. The grill pan is placed on the runner supports and should be correctly positioned under the grill element. Leave the control at HIGH for toast, sealing and fast cooking of foods. For thicker foods requiring longer cooking, turn the control to a lower setting after the initial sealing on both sides at setting HIGH. The thicker the food the lower the control should be set.

Note: ALWAYS have the door open when grilling. If closed a thermal device will operate. Allow cooker to cool and try again.

Grill pan handle

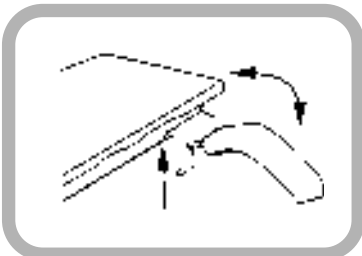

Remember to switch off the grill control at the end of cooking.

The grill pan handle is detachable from the pan, to facilitate cleaning and storage. The handle can be either detachable from or fixed to the pan. For a fixed handle remove the screw and washers from the grill pan bracket, tilt the handle over the recess adjacent to the bracket.

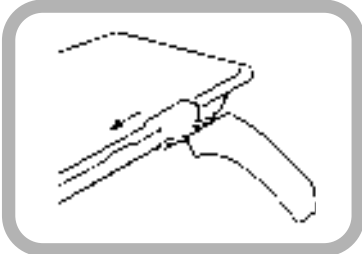

Slide the handle towards the centre of the pan and let the handle locate over the bracket.

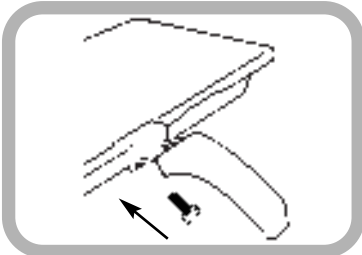

Replace screw and washers and ensure that they are fully tightened up. For a detachable handle remove screw and washers from grill pan and discard.

Warning: Ensure when using grill pan handle in the detachable manner it is centralised and secure.

Guide To Grilling

Pre - heat the grill for 5 minutes on maximum control setting before grilling

GRILL CHART

Food	Grill Setting	Approximate Cooking time
Toasting of Bread products	High	3 - 10 mins.
Small cuts of meat, sausages, bacon, etc.	Med - High	15 - 20 mins.
Chops etc. Gammon steaks Chicken pieces	Med	20 - 25 mins. Wire food support used in upturned position for chicken.
Fish: fingers Whole Fillets	Med	10 - 20 mins. Whole fish and fillets placed in the base of the grill pan.
Fish in breadcrumbs	Med	15 - 20 mins.
Pre - Cooked potato products	Med	15 - 20 mins.
Pizzas	Med	12 - 15 mins. in the base of the grill pan.
Browning of food	High	8 - 10 mins. Dish placed directly on base of the grill pan and pan placed on the base of the grill compartment.

The settings in the above guide have been developed to cook food successfully without excessive fat spitting and splashing.

Oven

Oven Control

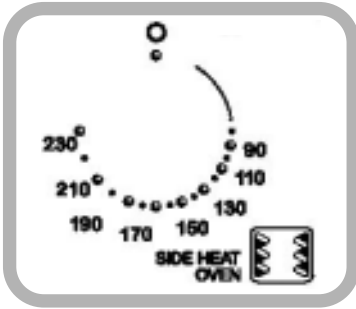

With the oven door closed, heating of the oven is achieved by turning the control clockwise to the required 'oven temperature' scale on the control panel, as recommended in the temperature charts. The pilot light will immediately come on and go off during cooking as the thermostat maintains the correct temperature.

Note: At the end of the cooking period there may be a momentary puff of steam when the oven door is opened. This will disperse in a few seconds and is perfectly normal characteristics of an oven with a good door seal.

Note: Remember to switch off the oven control after cooking is finished.

Oven Cookery Notes

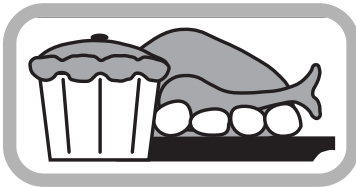

To prepare meat for roasting in your electric oven

The 'oven temperature charts' are a guide only, giving approximate cooking temperatures and times. To suit personal taste and requirements, it may be necessary to increase or decrease temperatures by 10°C.

Wipe the joint, dry well with a clean cloth, kitchen tissue, etc., and weigh it. Meat which has been stored in a refrigerator, should be allowed to come to room temperature for approximately 30 minutes before cooking. **Always completely thaw frozen meat before cooking.** Beef, lamb and mutton may be lightly floured, but pork should have the rind scored, brushed over lightly with olive oil, and sprinkled with salt – for crisp crackling.

Place the joint in a suitably sized meat pan (a small joint in a large meat pan causes unnecessary oven splashing). Small joints weighing less than 1.5kg (3lbs) may be pot roasted. Additional fat should not be used, except for veal, very lean meat, poultry, which can either be 'larded' with fat bacon, or brushed over **very sparingly** with melted fat/cooking oil. When potatoes are roasted round the joint, they only require to be coated in melted fat/cooking oil. It is not necessary to baste, when roasting in an electric oven, and liquid/stock should not be added to the meat pan.

Oven Cookery Notes

Temperature and Time

The secret of succulent, tender meat, is not to roast quickly at too high a temperature. Best results are obtained when roasting is carried out at low temperatures. When a lower temperature is used, joint loses less weight, is more tender (too high a temperature causes meat to be tough and dry), and the splashing of fat onto oven interior is reduced. When a complete meal is being cooked in the oven, cooking time may need to be increased, and temperature may need to be raised for approximately the last 30 minutes of the cooking period (for instance when cooking Yorkshire pudding to serve with roast beef).

The times and temperature suggested should be used as a guide but may vary according to:-

1. Whether you prefer meat rare, medium or well done.
2. The size and shape of your joint.
 - a) A short thick joint requires a longer cooking period than a long thin joint.
 - b) A small joint under 1.5kg (3lbs) takes longer per 450g (1lb) than a large one, whereas a large joint over 3kg (6lbs) will cook in the time given for 'minutes' per 450g (1lb) without the 'minutes' over added.
 - c) Boned/rolled and stuffed joints take longer to cook through than those with a bone. (The weight of stuffing should be added to the oven ready weight of meat/poultry to calculate roasting times.)

Meat pan and rod shelves

Never use meat pans larger than 390 x 300mm (15"x12") and baking trays no larger than 330x255mm (13"x10"), these should be positioned centrally on the oven shelf. Food should not be placed directly on the floor of the oven. To avoid unnecessary cleaning, rod shelves which are not in use, should be removed from the oven.

Temperature Chart – Baking

OVEN

Food	Preheat	Temperature and Time	Position in Oven from Bottom
Scones	Yes	220/230°C approx. 10-15 mins	Runners 1 and 4
Small Cakes	Yes	190/200°C approx. 20-25 mins	Runners 1 and 4
Victoria Sandwich	Yes	180/190°C 6 1/2" – 7" tins approx. 20 mins 8" – 8 1/2" tins approx. 30 mins	Runners 1 and 4
Sponge Sandwich (Fatless)	Yes	190/200°C 7" tins 15-20 mins	Runners 1 and 4
Swiss Roll	Yes	200/210°C approx. 10-15 mins	Runner 4
Semi-rich Cakes (large)	Yes	160/170°C 6 1/2" – 7" tins 1 1/4 – 1 1/2 hrs 8" – 9" tins 2 – 2 1/2 hrs	Runner 3
Christmas Cake	Yes	140/150°C – dependant on size and richness of mixture	Runner 3
Shortcrust Pastry	Yes	200/210°C depending on use	Runners 2 and 5
Puff Pastry	Yes	220°C approx. – depending on use	Runners 2 and 5
Yorkshire Pudding	Yes	210/220°C 45-50 mins	Runner 5
Individual Yorkshire Puddings	Yes	210/220°C approx. 20-25 mins	Runner 5
Milk Pudding	Yes	150/160°C approx. 2 – 2 1/2 hrs	Runner 2
Baked Egg Custard	Yes	150/160°C approx. 45-55 mins	Runner 2
Bread (full oven) Bread (Single loaf)	Yes	230°C 50-60 mins reducing to 210/220°C 230°C 45-50 mins after first 10 minutes	Runners 1 and 4
Meringues	Yes	100/110°C Large 3 1/2 - 4 1/2 hrs Small 2 1/2 - 3 hrs	Runner 1

Note: Always refer to cookery notes before using oven. If soft tub margarine is used for cakes, temperatures recommended by the manufacturers should be followed. Temperatures recommended in this chart refer to cakes made with block margarine or butter only.

Temperature Chart – Meat

OVEN			
Food	Preheat	Temperature and Time	Position in Oven from bottom
Beef	Yes	190/200°C approx. 25-30 mins per 450 (1lb) + 25 mins extra	In meat pan on runner 2
Lamb	Yes	190/200°C approx. 25-30 mins per 450 (1lb) + 25 mins extra	
Pork	Yes	190/200°C approx. 30-35 mins per 450g (1lb) + 30 mins extra	
Veal	Yes	190/200°C approx. 25-35 mins per 450g (1lb) + 30 mins extra	
Poultry/Game	Yes	180/190°C approx. 18-20 mins per 450g (1lb) + 20 mins extra	
Turkey	Yes	up to 5.5kg (12lb) allow 22 mins per 450g (1lb) at 190°C e.g. 5kg (11lb) = 242 mins over 5.5kg (12lb) allow 16 mins per 450g (1lb) at 180°C e.g. 10kg (22lb) = 352 mins	
Casseroles/Stews	Yes	140/160°C approx. according to quantity	Runner 3
<p>If using aluminium foil--</p> <ol style="list-style-type: none"> 1) Remember it is important to increase the cooking time by one third. 2) Never allow foil to touch sides of oven. 3) Never cover oven interior with foil. 4) Never cover oven shelves with foil. 			

Care and Cleaning



TURN OFF THE MAIN SWITCH BEFORE CLEANING. BEFORE SWITCHING ON AGAIN, ENSURE THAT ALL CONTROLS ARE IN THE OFF POSITION.

NEVER USE BIOLOGICAL WASHING POWDER, HARSH ABRASIVES, SCOURING PADS, AEROSOL CLEANERS OR OVEN CHEMICAL CLEANERS OF ANY KIND UNLESS SPECIFIED BELOW.

CLEANING MATERIALS TO AVOID

1. Plastic or nylon pads / scourers, these may scratch the surface.
2. Household abrasive powders.
3. Oven chemical cleaners, aerosols and oven pads.
Caustic cleaners such as these will etch the surface and attack the metal frame.
4. Bath and sink cleaners may mark the surface.

ELECTRIC SEALED HOTPLATES

The cleaning of sealed hotplates should be done when they are cold, using a soap filled Brillo pad, following the grain of the hotplate. This will ensure that any stubborn, burnt on spillages are removed. Wipe over with a damp clean cloth, making sure that all the cleaner has been removed. Finally, turn on hotplate to warm for a few minutes, then smear with a little cooking oil to provide a protective coating, or the restorative agent Homecare Four Hob, available from Credacare Spares or leading supermarkets. The bezels will mellow with use to a burnished gold colour, a soap filled Brillo pad will help to keep them bright, care should be taken not to damage the vitreous enamel hob surface.

GRILL

Remove the grill pan and the wire grid food support, it is best to wash these items immediately after use to prevent stains from being burnt on when used again. Wipe out the Grill compartment, use a fine steel wool soap pad to remove stubborn stains from the grill runners the grill deflector plate and the floor of the compartment.

CONTROL PANEL

Wipe over the control panel with a damp cloth and polish with a dry cloth. **Do not use** cream cleaners, oven cleaners or aerosols, scouring pads or abrasive powder for cleaning the plastic knobs as damage will occur.

OVEN DOORS

Wipe over the door outer panel with a cloth wrung out in hot soapy water, then afterwiping with a cloth wrung out in clear water, dry with a soft clean cloth.

Do not use scouring pads or abrasive powder which may scratch the surface.

Take care during cleaning not to damage or distort the Door Seal. Do not lift the Door Seal from the Oven Front Frame, if necessary remove the seal by carefully unhooking the corner clips.

Care and Cleaning

How 'Credaclean' Works

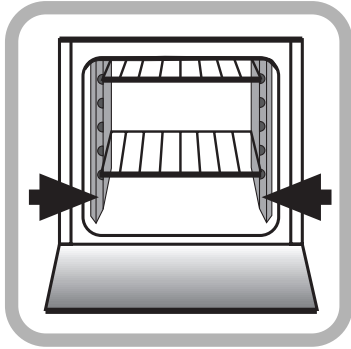

The surface of the 'Credaclean' oven liners are treated on the mottled face with a special vitreous enamel which absorbs cooking soils. At temperatures of 220°C (425°F) or above, the special surface enables these soils to be slowly destroyed. The higher the temperature the more effective it is. In most cases normal cooking operation at this temperature will permit this cleaning operation to proceed during cooking. However if higher cooking temperatures are not used regularly it may be necessary, to prevent heavy soiling, to run the oven control at maximum setting for a couple of hours. This may be necessary once a month or once every two or three months depending on the type and amount of oven cooking.

Oven Liners – Sides

It should not normally be necessary to clean the 'Credaclean' panels in water. If desirable remove the rod shelves and the side panels and wash them in warm soapy water, followed by rinsing in clean water.

Cleaning Materials to avoid

1. Plastic or nylon pads, scourers, these may scratch the surface.
2. Household abrasive powders.
3. Oven chemical cleaners, aerosols and oven pads.
4. Caustic cleaners, these will etch the surface and attack the metal frame.
5. Bath and sink cleaners may mark the surface.

Note: We do not recommend the use of decorative covers over the hot hotplates as these can hold condensation and cause corrosion. Accidental operation with a cover in place can cause intense heat. Never place saucepan lids on the hotplates, as this may cause corrosion.

Note: Care must be taken to ensure that the rating plate label edges are not lifted during cleaning and that the lettering is not blurred or removed.

Cooking Results Not Satisfactory?

Problem	Check
Grilling Uneven cooking front to back	Ensure that the grill pan is positioned correctly.
Fat splattering	Ensure the grill is not set to too high a temperature.
Oven Baking Uneven rising of cakes	Ensure that the oven shelves are level by using a spirit level on the rod shelf and adjusting, using suitable packing, e.g. wood, under the feet of the appliance. This should be checked both left to right and front to back.
Sinking of cakes	The following may cause cakes to sink: 1. Cooking at too high a temperature. 2. Using normal creaming method with soft margarine.
Over/Under cooking Fast/Slow cooking	Refer to the cooking times and temperatures given in the oven temperature charts, however, it may be necessary to increase or decrease temperatures by 10°C to suit personal taste. Do not use utensils greater than 75mm (3") in height for roasting
Nothing Works	Is the main cooker wall switch turned on? There may be no electricity supply.
Grill keeps turning on and off	When the grill control is operated at a setting less than "High" this is normal regulator operation, not a fault.

Should you require any advice concerning cooking, please contact:–

The Home Economist
 PO Box 5
 Blythe Bridge
 Stoke-on-Trent, ST11 9LJ

Something Wrong with your Cooker?

Before contacting your Creda Service Centre/Installer, check the problem guide below.

Problem	Check
Slight odour or small amount of smoke when using the cooker for the first time.	This is normal and should cease after a short period.
Cooker does not work at all.	Check that the switch on the control unit is in the on position.
Oven temperature seems too high or too low.	Check that the temperature has been set in accordance with the temperature charts. It may be necessary to increase or decrease the recommended temperature by up to 10°C to suit your taste.
Oven does not cook evenly.	Check that the temperature and shelf position are as recommended in the temperature charts. Check that the containers being used in the oven allow sufficient air flow around them. Check that the cooker is level.
Hotplates are slow to boil or will not simmer.	Check that your pans conform to the recommendations in these instructions.
Grilling is uneven.	Check that the grill pan has been correctly positioned.
Marks appearing on hotplates. Can not clean hob / hotplates.	The hob surround can be cleaned with warm soapy water and a cream cleaner, such as Jif. The sealed hotplates should be cleaned regularly (Please refer to the Care and Cleaning section for further information). Please note that replacement hob cleaning kits are available from our parts department, under part number: 6400001
Grill not working.	Grill will not work unless the Grill door is in the grill position (see Grilling section of this book).
Condensation on the wall at the rear of the cooker.	Steam and/or condensation may appear from the vent at the rear of the appliance when using an oven particularly for foods with a high water content e.g. frozen chips, roast chicken etc. This is normal and any excess should be wiped off.
Steam / Condensation in the oven after use.	Steam is a by-product of cooking any food with a high water content. To help minimise always: a) Try to avoid leaving food in the oven to cool after being cooked. b) Use a covered container, wherever possible

If you have been through the above list and there is still a problem. You should identify your Service Agent using the list on the back page and contact your Local Service Office.

Key Contacts

Service

Creda has the largest appliance manufacturer's service team in Europe, trained specialists directly employed by us to ensure your complete confidence.

Repair Service

UK: 08709 066 066

Republic of Ireland: 1850 302 200

You will be asked for the following information:-

Name, address and postcode.

Telephone number

Model / Serial number of the appliance

Clear and concise details of the query or fault

Place and Date of purchase

(Please keep the receipt as evidence will be required when the engineer calls).

Extended Warranty

To join: UK 08709 088 088

Republic of Ireland: 1850 502 200

Genuine Parts & Accessories

Mail Order Hotline

UK: 08709 077 077

Republic of Ireland: (01) 842 6836

For further product information 08701 54 64 74

All Creda Services are offered as an extra benefit and do not affect your statutory rights.

Creda

General Domestic Appliances Limited, Morley Way, Peterborough, PE2 9JB